

NOUVEAUTÉS

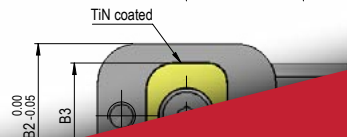
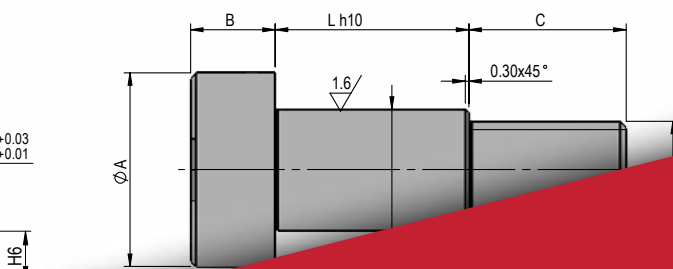
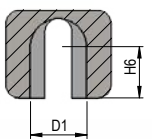
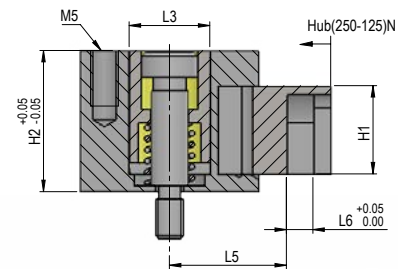
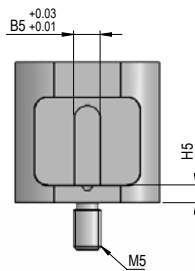
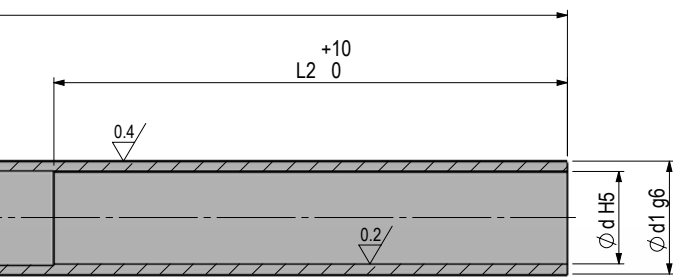
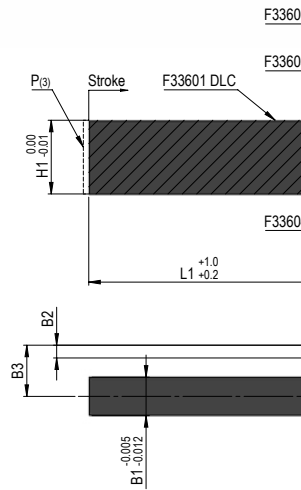
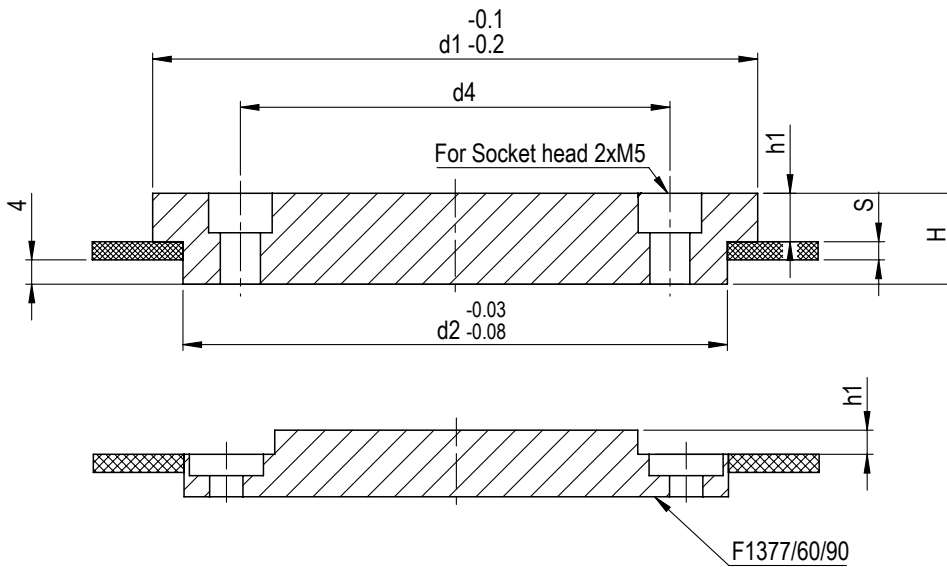
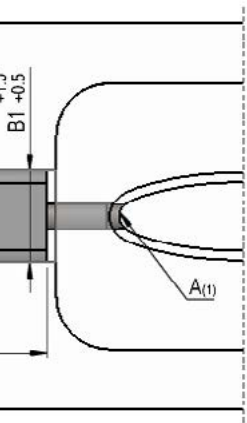
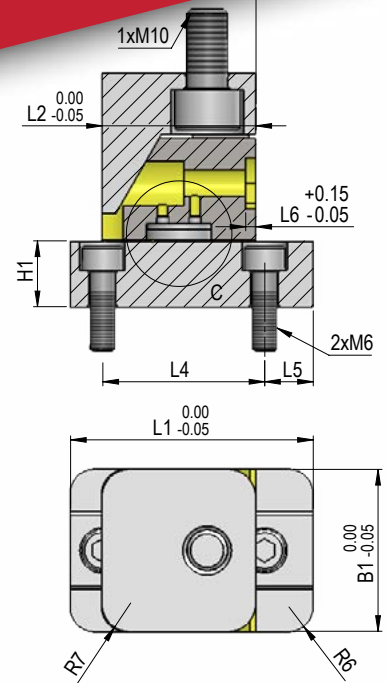
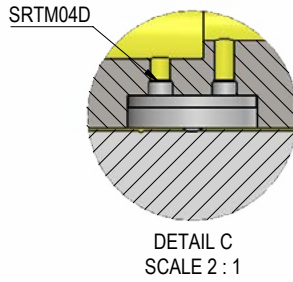
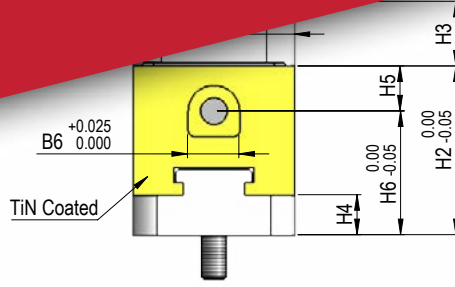
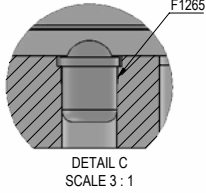
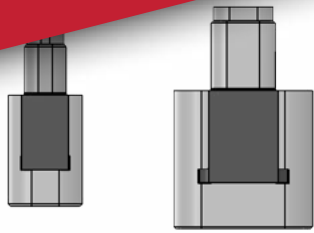
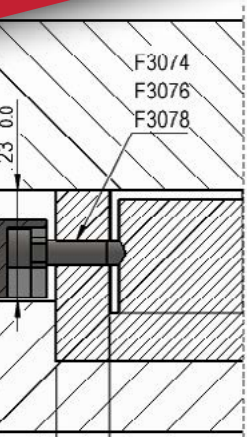

EXTENSION DE LA GAMME DE COMPOSANTS

NOUVEAUTÉS POUR L'OFFRE DE COMPOSANTS DME

Les solutions d'alignement de moules DME comptent maintenant 5 NOUVEAUX MODULES COULISSANTS de plus. La gamme des kits d'alignement compacts avec revêtement TiN ou DLC vous permet de créer différentes formes latérales et convient à de nombreuses applications différentes. La gamme de solutions de guidage de moules s'élargit avec de nouveaux types et de nouvelles tailles d'éjecteurs et de tubulaires, de bagues de centrage, de vis épaulées, dispositifs de retenue pour broche inclinée ou de clavettes avec plaque d'usure.

Découvrez les nouveaux produits DME ici !

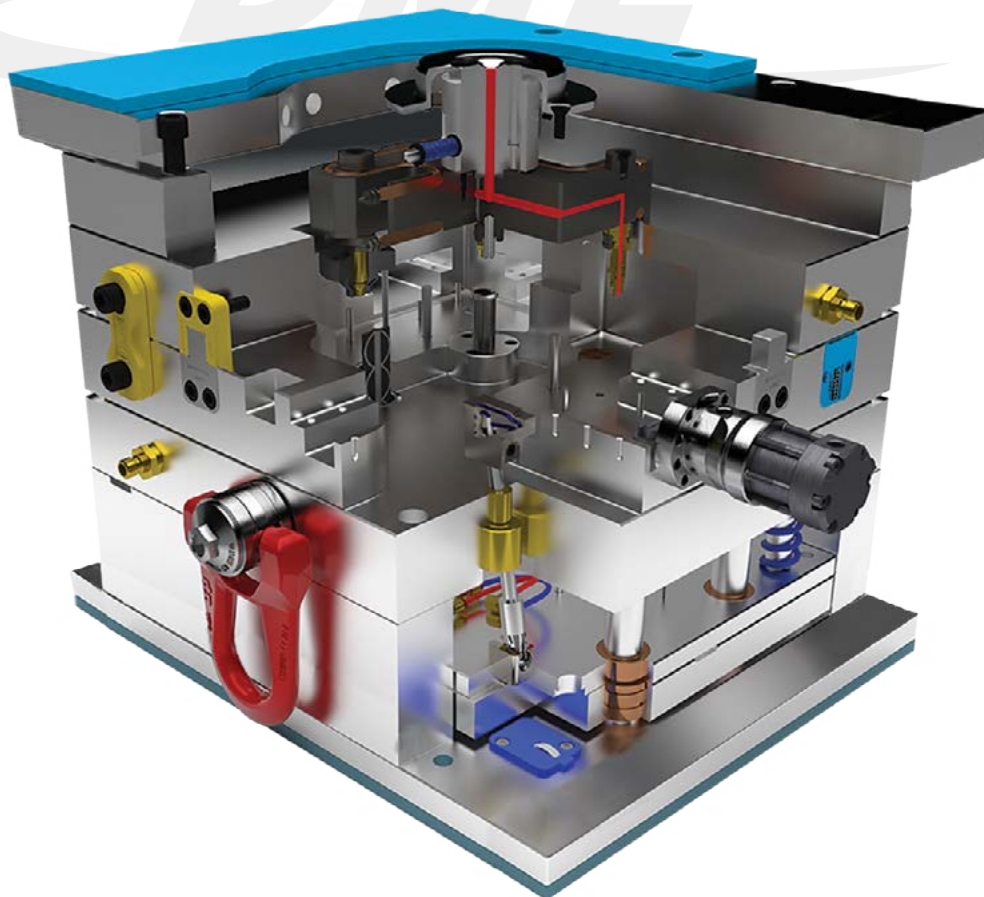

CONTENT:

Unités coulissantes 3

F3070 3
F3072 4
F3080 5
F3330 6
F3360 7

Manchon d'éjecteur 8

KSS 8

Broche-noyau 9

ERV 9

Retenues 10

F3060 10
F3024 11

Bagues de centrage 12

F1377 12

Des vis 13

GM 13

UNITÉ COULISSANTE AVEC RESSORT DE RAPPEL

F3070

Mat: 1.7228, 1.2344

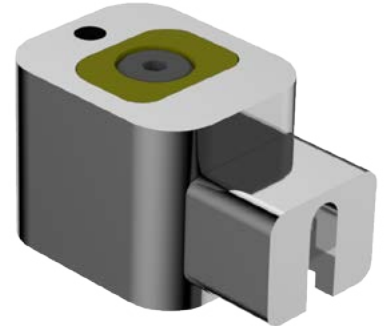
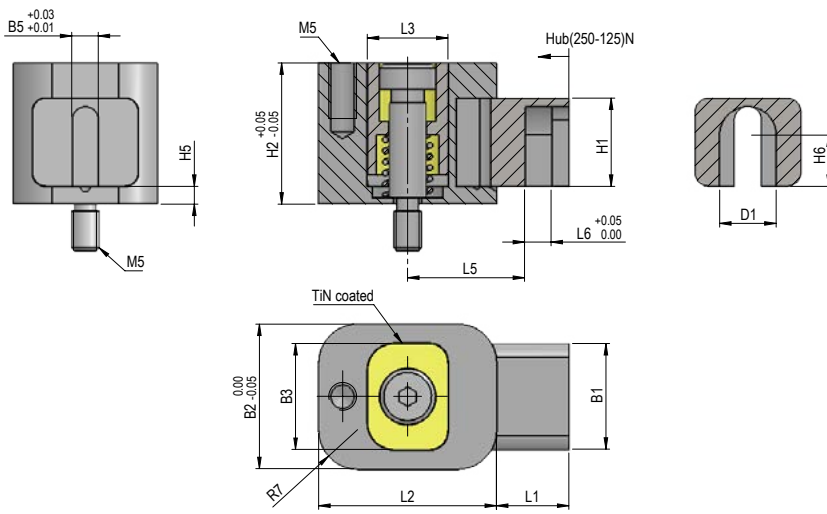

REF	Course	D1	L6	H6	B5	H5	B1	L1	H1	L5	B2	L2	H2	B3	L3
F307005-80	5,8	10,16	4,78	9,22	4,76	3,18	19	13	15,88	21,03	26	32	25,4	19,1	14,5

Notes :

1. A : Position d'arrêt, charge maxi 275 N
2. FL : Longueur de guidage mini 1,5x diamètre du noyau
3. 2 ressorts de rappel F30704 fournis

CAD reference point

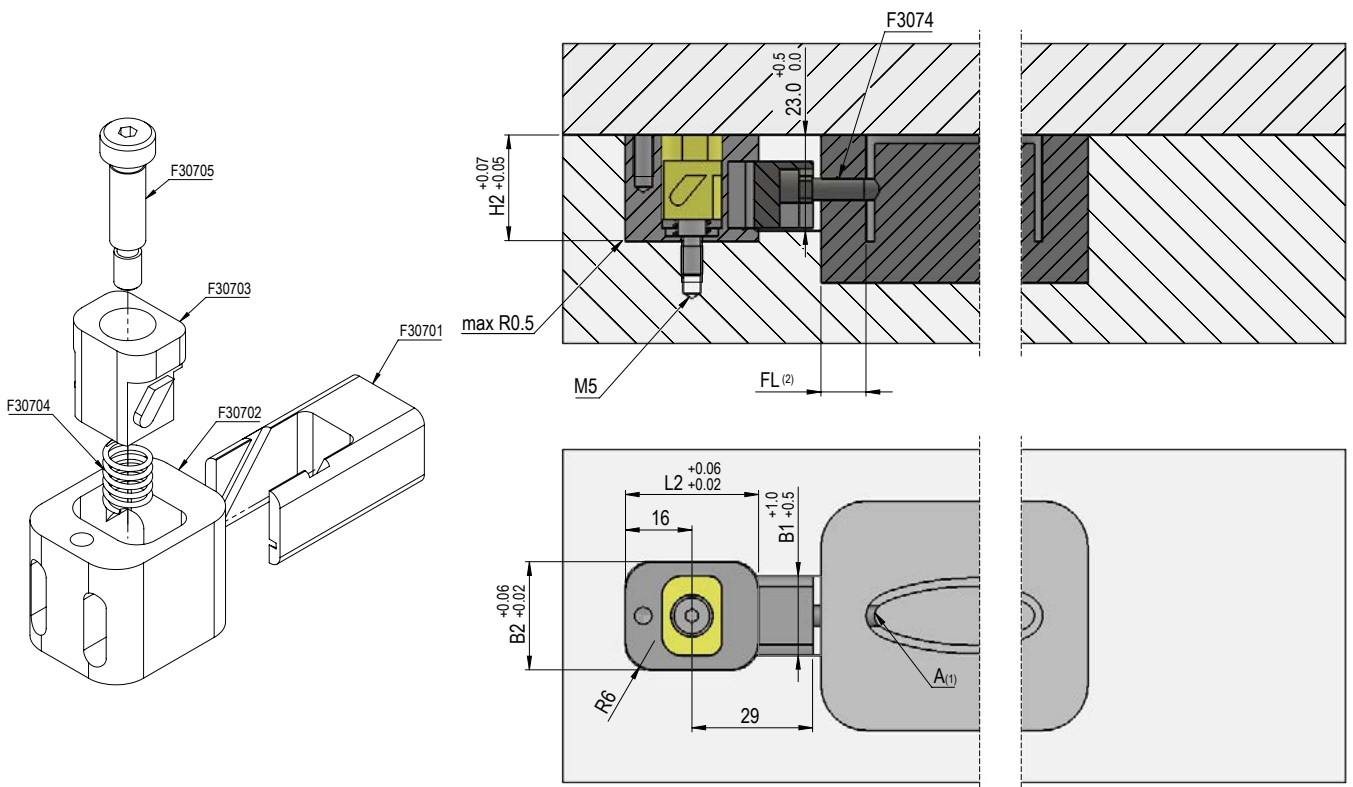

Mat.: 1.7228, 1.2344

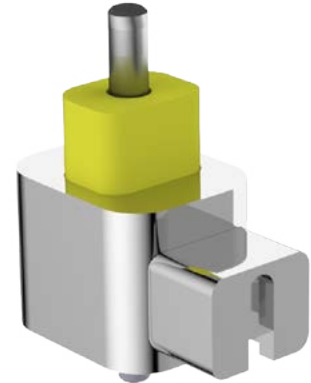
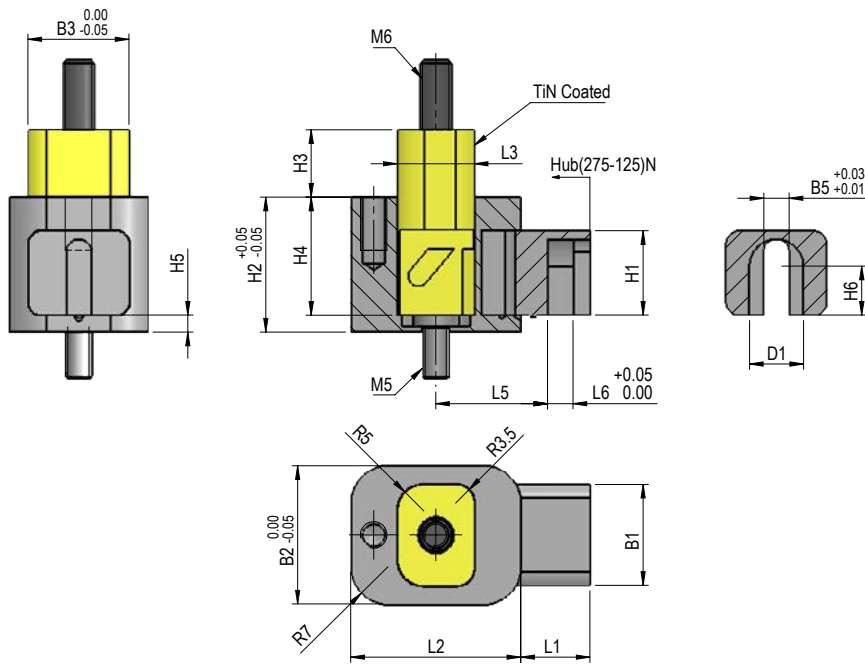

REF	Course	H3	D1	L6	H6	B5	H5	B1	L1	H1	L5	B2	L2	H2	B3	L3	H4
F307205-8012-70	5,8	12,7	10,16	4,78	9,22	4,76	3,175	19	13,02	15,88	21,03	26	32	25,4	19,1	14,5	22,23
F307205-8077-80	5,8	77,8	10,16	4,78	9,22	4,76	3,175	19	13,02	15,88	21,03	26	32	25,4	19,1	14,5	22,23

Notes :

1. A : Position d'arrêt, charge maxi 275 N
2. FL : Longueur de guidage mini 1,5x diamètre du noyau
3. M : Trou de fixation pour broches-noyaux de plus de 44 de long
4. H3 : Fournir un précharge sur le noyau si nécessaire

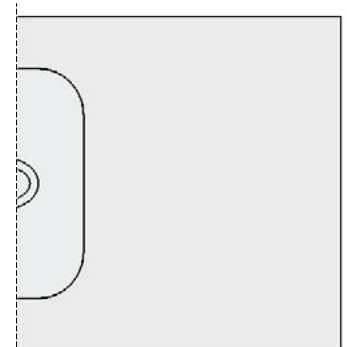
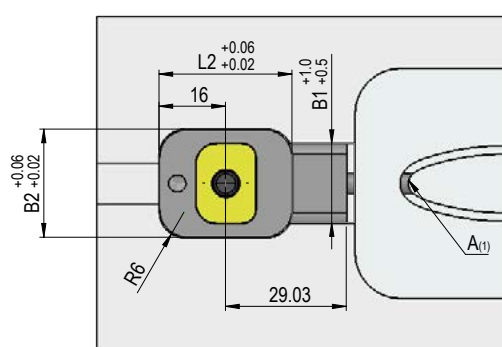
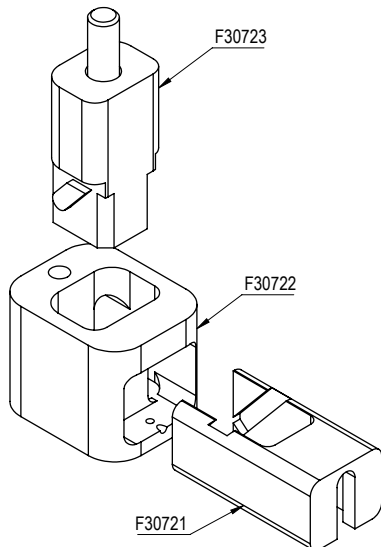
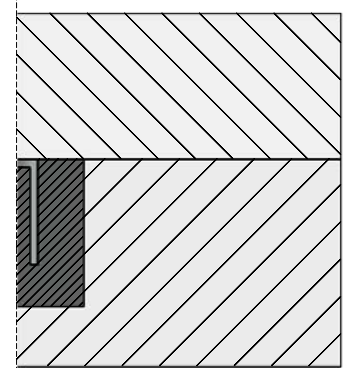
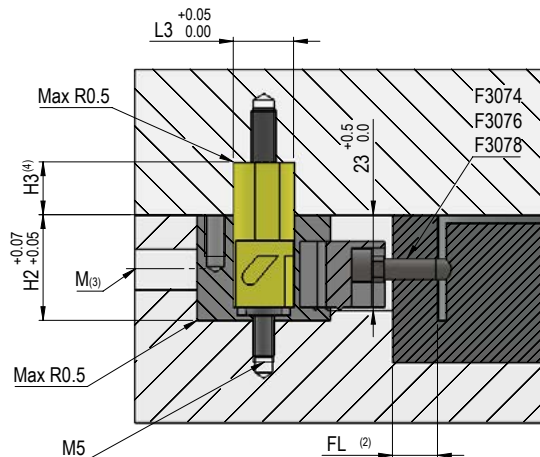
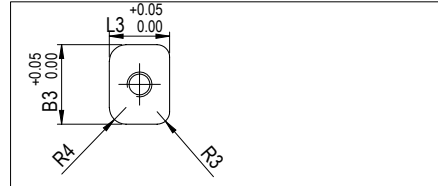

CAD reference point

UNITÉ COULISSANTE AVEC CLAVETTE

F3080

Mat: 1.7228, 1.2344

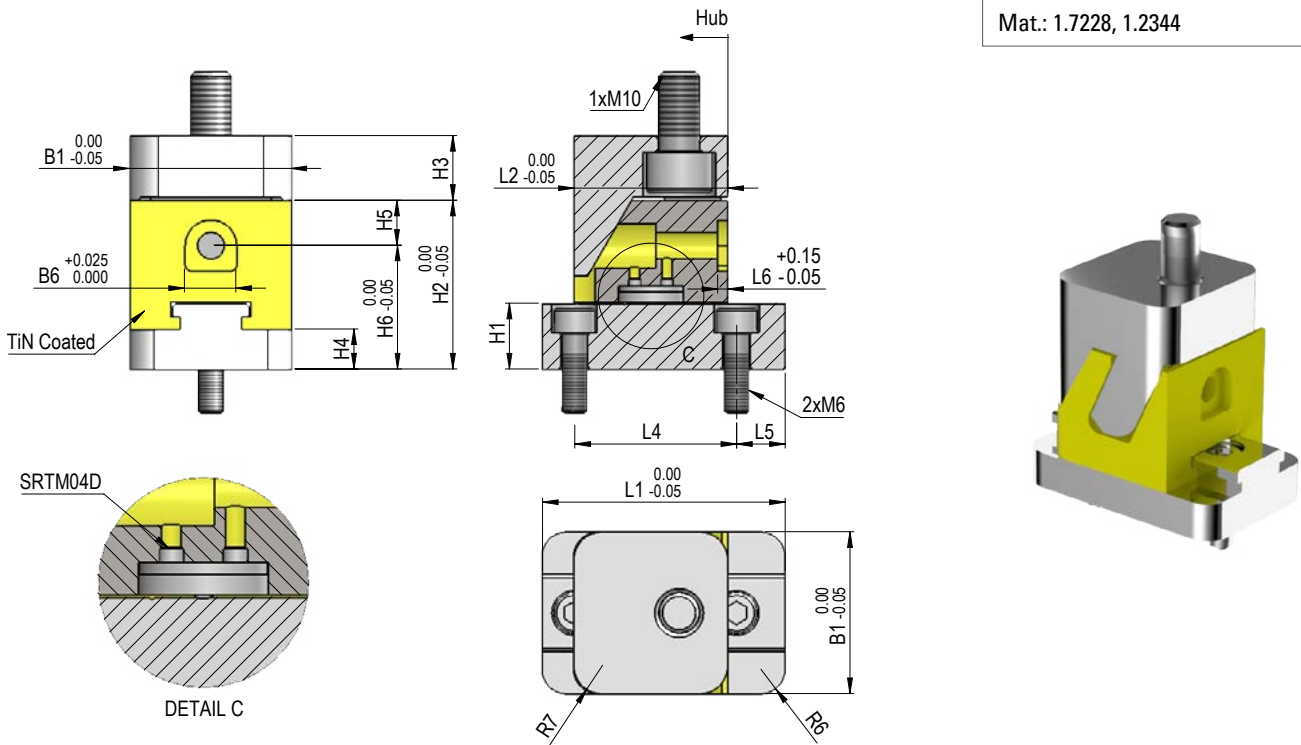

REF	Course	H3	L7	B6	L6	H6	L8	H5	L4	H1	L5	H4	L2	B1	L1	H2
F308006-35016-0	6,35	16	14,15	12,7	2,5	30,6	12	11,1	40	16,3	12	9,9	38	40	60	41,7
F308006-35106-0	6,35	106	14,15	12,7	2,5	30,6	12	11,1	40	16,3	12	9,9	38	40	60	41,7
F308018-00020-5	18	20,5	6	12,7	2,5	34,8	14	11,35	42	20,6	12	14,1	40	40	64	46,15

Notes :

1. FL : Si nécessaire, prévoir un dégagement pour l'assemblage
2. T : Si nécessaire, fournissez une précharge sur le noyau

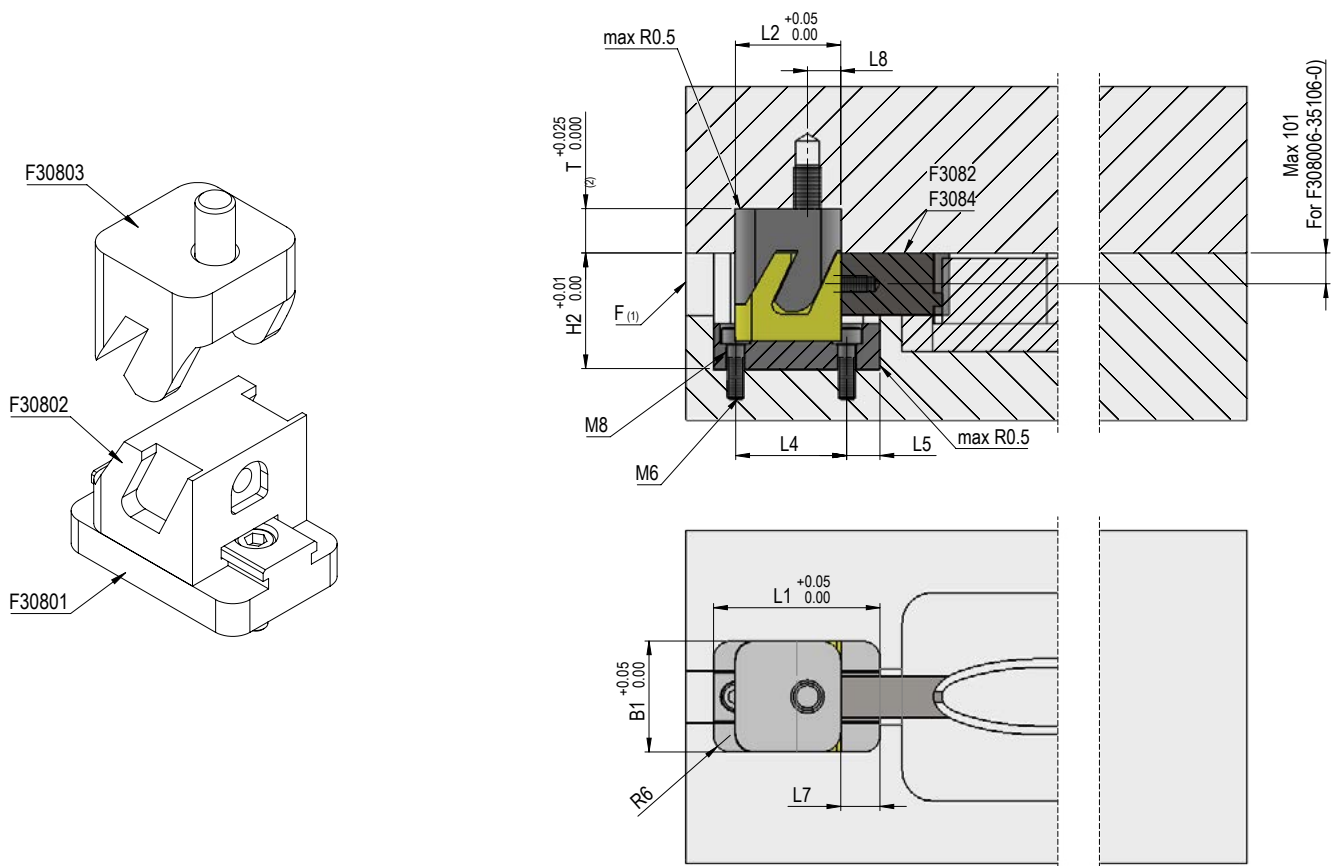

CAD reference point

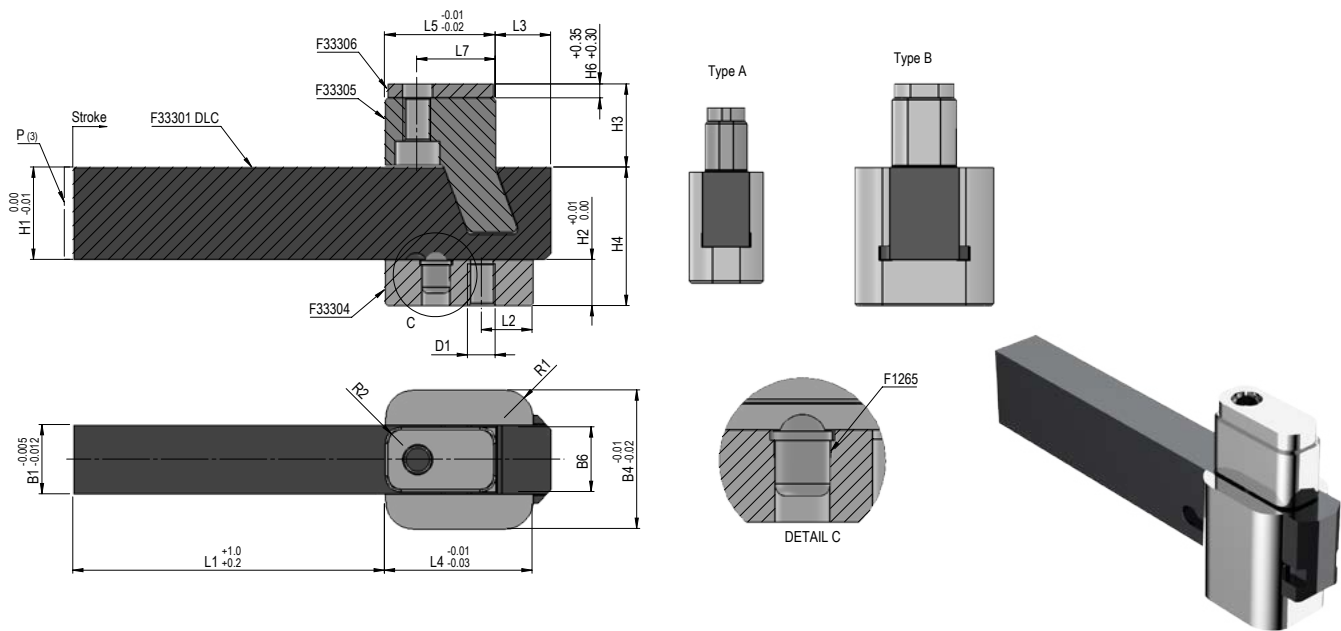

REF	Type	H1	B1	Course	B4	L4	R1	H2	H4	D1	L2	B6	L5	R2	L7	L1	H6 ⁽¹⁾	L3	H3	D2	B7	L8 ⁽²⁾
F333016102-7	A	16	10	2,7	16	20	5	8	24	M6	5,5	9	20	3	15	60	3	5	14	M4	12	8,3
F333018113-4	B	18	11	3,4	25	25	6	10	28	M6	7,5	10	20	3,5	15	67,5	3	8,5	18	M4	18	7,6
F333020154-4	B	20	15	4,4	30	32	6	10	30	M6	11	14	24	3,5	17	67,5	3	12	18	M5	22	9
F333025185-4	B	25	18	5,4	36	40	6	13	38	M8	15	17	30	3,5	22	70	3	16	18	M6	25	11,8
F333028226-4	B	28	22	6,4	40	40	7	12	40	M8	10	21	30	4	23	80	3	13	18	M6	28	10,2

Notes :

1. H6 : Avec tolérance pour l'ajustage
2. L8 : Butée
3. T : Précharge

Précharge	
p ⁽³⁾	H6
0,02	3,055
0,04	3,11
0,06	3,165

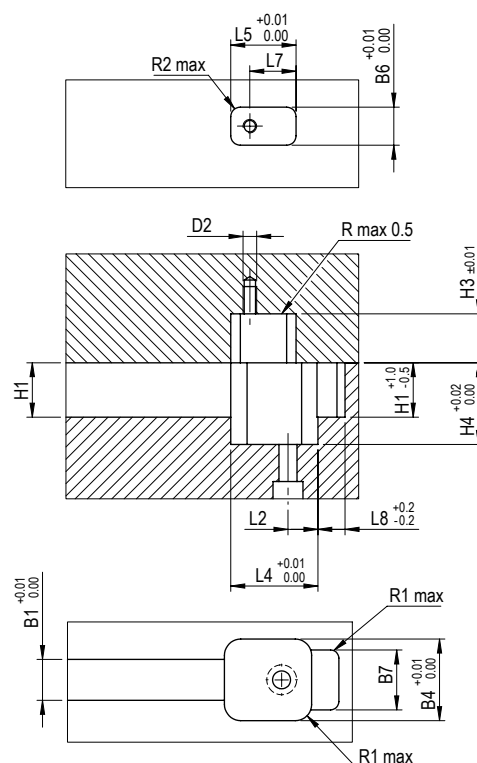

KIT DE GLISSIÈRE COMPACTE

F3360

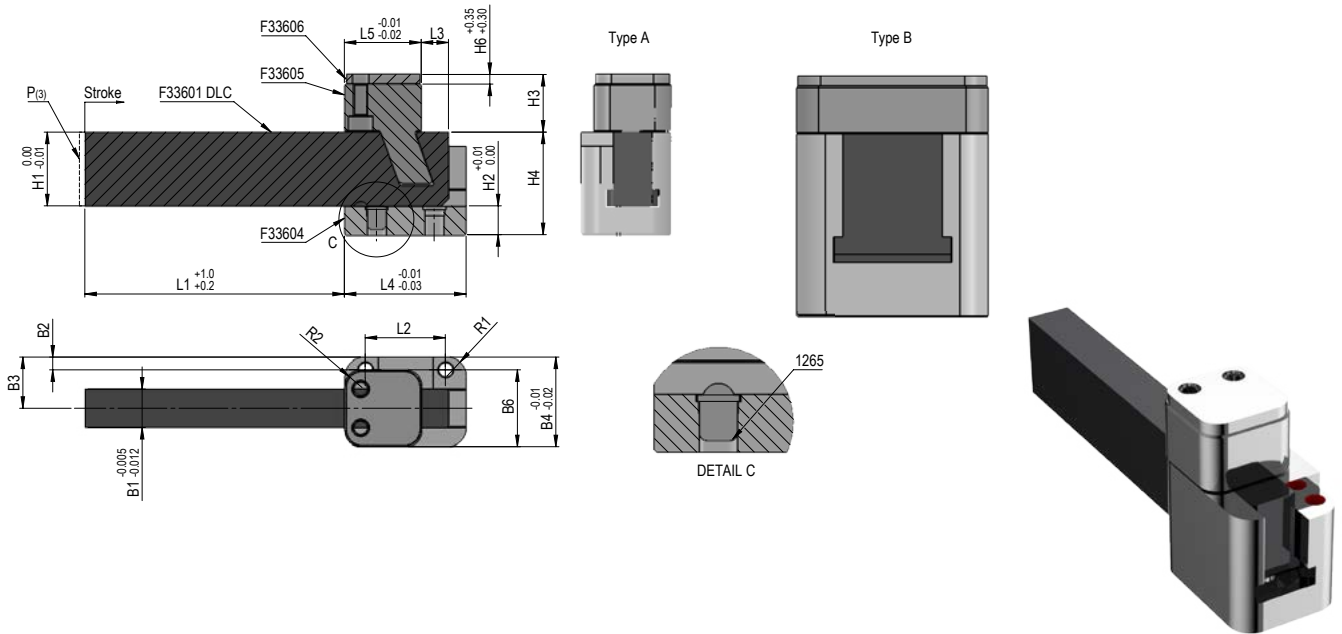

REF	Type	H1	B1	Course	B4	L4	B3	R1	H2	B2	H4	L2	B6	L5	R2	L1	H6 ⁽²⁾	L3	H3	D1	D2	B7	L7
F3360231204_9	A	23	12	4,9	28	38	16	6	9	4	32	25	24	24	5	81	3	8,5	18	M4	M4	12	19
F3360302206_9	A	30	22	6,9	42	50	25	7	12	7	42	34	34	32	6	105	3	10,5	18	M4	M4	20	25
F3360403117_4	B	40	31	17,4	60	68	30	9	17	46	57	46	60	45	7	131	3	5	18	M6	M6	46	31

Notes :

1. H6 : Avec tolérance pour l'ajustage
2. L8 : Butée
3. T : Précharge

Précharge	
p ⁽³⁾	H6
0,02	3,055
0,04	3,11
0,06	3,165

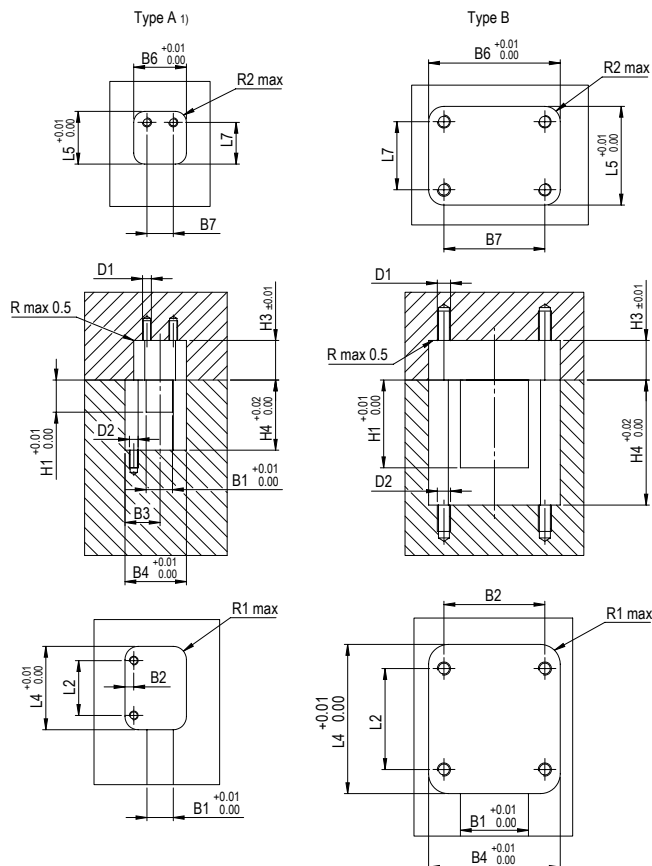

MANCHON D'ÉJECTEUR

ÉJECTEUR TUBULAIRE TREMPÉ SANS ÉPAULEMENT
KSS

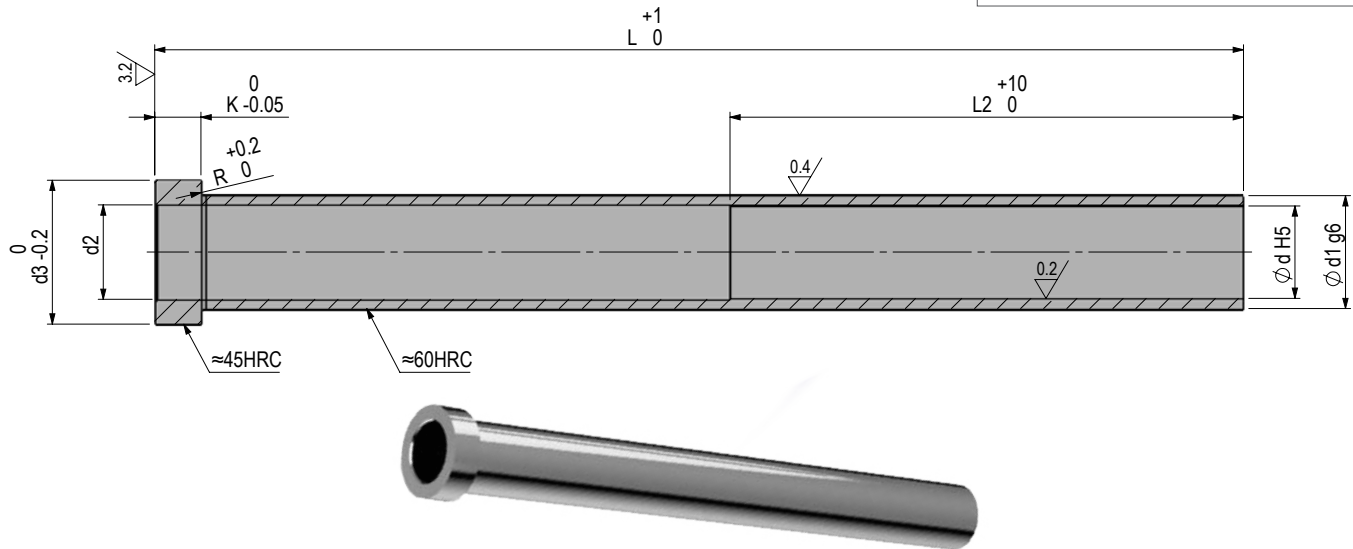
 Mat.: 1.2210
 ≈ ISO 8405 (DIN 16756)

REF	d	d1	L	d2	d3	L2	K	R
KSS01503075	1,5	3	75	1,8	6	35	3	0,3
KSS01503100	1,5	3	100	1,8	6	35	3	0,3
KSS01503125	1,5	3	125	1,8	6	35	3	0,3
KSS01503150	1,5	3	150	1,8	6	35	3	0,3
KSS01503175	1,5	3	175	1,8	6	35	3	0,3
KSS02004075	2	4	75	2,4	8	35	3	0,3
KSS02004100	2	4	100	2,4	8	35	3	0,3
KSS02004125	2	4	125	2,4	8	35	3	0,3
KSS02004150	2	4	150	2,4	8	35	3	0,3
KSS02004175	2	4	175	2,4	8	35	3	0,3
KSS02504075	2,5	4	75	2,9	8	35	3	0,3
KSS02504100	2,5	4	100	2,9	8	35	3	0,3
KSS02504125	2,5	4	125	2,9	8	35	3	0,3
KSS02504150	2,5	4	150	2,9	8	35	3	0,3
KSS02504175	2,5	4	175	2,9	8	35	3	0,3
KSS02504200	2,5	4	200	2,9	8	35	3	0,3
KSS03005075	3	5	75	3,4	10	45	3	0,3
KSS03005100	3	5	100	3,4	10	45	3	0,3
KSS03005125	3	5	125	3,4	10	45	3	0,3
KSS03005150	3	5	150	3,4	10	45	3	0,3
KSS03005175	3	5	175	3,4	10	45	3	0,3
KSS03005200	3	5	200	3,4	10	45	3	0,3
KSS03505075	3,5	5	75	3,9	10	45	3	0,3
KSS03505100	3,5	5	100	3,9	10	45	3	0,3
KSS03505125	3,5	5	125	3,9	10	45	3	0,3
KSS03505150	3,5	5	150	3,9	10	45	3	0,3
KSS03505175	3,5	5	175	3,9	10	45	3	0,3
KSS03505200	3,5	5	200	3,9	10	45	3	0,3
KSS04006075	4	6	75	4,4	12	45	5	0,5
KSS04006100	4	6	100	4,4	12	45	5	0,5
KSS04006125	4	6	125	4,4	12	45	5	0,5
KSS04006150	4	6	150	4,4	12	45	5	0,5
KSS04006175	4	6	175	4,4	12	45	5	0,5
KSS04006200	4	6	200	4,4	12	45	5	0,5
KSS04006225	4	6	225	4,4	12	45	5	0,5
KSS04006250	4	6	250	4,4	12	45	5	0,5
KSS04506075	4,5	6	75	4,9	12	45	5	0,5
KSS04506100	4,5	6	100	4,9	12	45	5	0,5

REF	d	d1	L	d2	d3	L2	K	R
KSS04506125	4,5	6	125	4,9	12	45	5	0,5
KSS04506150	4,5	6	150	4,9	12	45	5	0,5
KSS04506175	4,5	6	175	4,9	12	45	5	0,5
KSS04506200	4,5	6	200	4,9	12	45	5	0,5
KSS04506225	4,5	6	225	4,9	12	45	5	0,5
KSS04506250	4,5	6	250	4,9	12	45	5	0,5
KSS05007100	5	7	100	5,3	12	50	5	0,5
KSS05007125	5	7	125	5,3	12	50	5	0,5
KSS05007150	5	7	150	5,3	12	50	5	0,5
KSS05007175	5	7	175	5,3	12	50	5	0,5
KSS05007200	5	7	200	5,3	12	50	5	0,5
KSS05007225	5	7	225	5,3	12	50	5	0,5
KSS05007250	5	7	250	5,3	12	50	5	0,5
KSS05508100	5,5	8	100	5,9	14	50	5	0,5
KSS05508125	5,5	8	125	5,9	14	50	5	0,5
KSS05508150	5,5	8	150	5,9	14	50	5	0,5
KSS05508175	5,5	8	175	5,9	14	50	5	0,5
KSS05508200	5,5	8	200	5,9	14	50	5	0,5
KSS05508225	5,5	8	225	5,9	14	50	5	0,5
KSS05508250	5,5	8	250	5,9	14	50	5	0,5
KSS06009100	6	9	100	6,4	14	50	5	0,5
KSS06009125	6	9	125	6,4	14	50	5	0,5
KSS06009150	6	9	150	6,4	14	50	5	0,5
KSS06009175	6	9	175	6,4	14	50	5	0,5
KSS06009200	6	9	200	6,4	14	50	5	0,5
KSS06009225	6	9	225	6,4	14	50	5	0,5
KSS06009250	6	9	250	6,4	14	50	5	0,5
KSS08012100	8	12	100	8,5	20	50	7	0,8
KSS08012125	8	12	125	8,5	20	50	7	0,8
KSS08012150	8	12	150	8,5	20	50	7	0,8
KSS08012175	8	12	175	8,5	20	50	7	0,8
KSS08012200	8	12	200	8,5	20	50	7	0,8
KSS10014100	10	14	100	10,5	22	50	7	0,8
KSS10014125	10	14	125	10,5	22	50	7	0,8
KSS10014150	10	14	150	10,5	22	50	7	0,8
KSS10014175	10	14	175	10,5	22	50	7	0,8
KSS10014200	10	14	200	10,5	22	50	7	0,8

CAD reference point

ÉJECTEUR AVEC SÉCURITÉ ANTI-ROTATION **ERV**

Mat: 1.2344

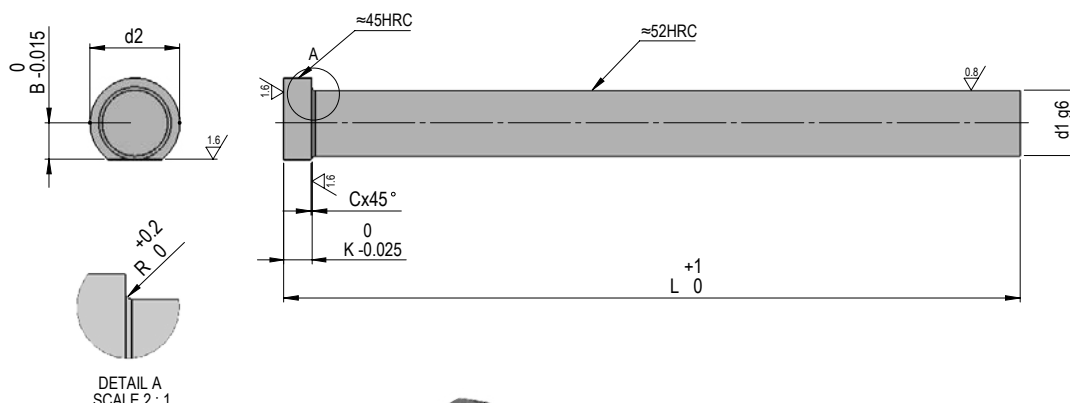

REF	d1	d2	L	B	C	K	R
ERV05015125	1,5	3	125	1,05	0,15	1,5	0,2
ERV05015200	1,5	3	200	1,05	0,15	1,5	0,2
ERV05016125	1,6	3	125	1,1	0,15	1,5	0,2
ERV05016200	1,6	3	200	1,1	0,15	1,5	0,2
ERV05018125	1,8	3	125	1,2	0,15	1,5	0,2
ERV05018200	1,8	3	200	1,2	0,15	1,5	0,2
ERV05020125	2	4	125	1,5	0,25	2	0,2
ERV05020200	2	4	200	1,5	0,25	2	0,2
ERV05022125	2,2	4	125	1,6	0,25	2	0,2
ERV05022200	2,2	4	200	1,6	0,25	2	0,2
ERV05025125	2,5	5	125	1,75	0,25	2	0,3
ERV05025200	2,5	5	200	1,75	0,25	2	0,3
ERV05027125	2,7	5	125	1,85	0,25	2	0,3
ERV05027200	2,7	5	200	1,85	0,25	2	0,3
ERV05030125	3	6	125	2	0,25	3	0,3
ERV05030200	3	6	200	2	0,25	3	0,3
ERV05032125	3,2	6	125	2,1	0,25	3	0,3
ERV05032200	3,2	6	200	2,1	0,25	3	0,3
ERV05035125	3,5	7	125	2,25	0,25	3	0,3
ERV05035200	3,5	7	200	2,25	0,25	3	0,3
ERV05037125	3,7	7	125	2,35	0,25	3	0,3
ERV05037200	3,7	7	200	2,35	0,25	3	0,3
ERV05040125	4	8	125	2,5	0,25	3	0,3
ERV05040200	4	8	200	2,5	0,25	3	0,3
ERV05042125	4,2	8	125	2,6	0,25	3	0,3
ERV05042200	4,2	8	200	2,6	0,25	3	0,3
ERV05045125	4,5	8	125	2,75	0,25	3	0,3
ERV05045200	4,5	8	200	2,75	0,25	3	0,3
ERV05050125	5	10	125	3,5	0,25	3	0,3
ERV05050200	5	10	200	3,5	0,25	3	0,3
ERV05052125	5,2	10	125	3,6	0,25	3	0,3
ERV05052200	5,2	10	200	3,6	0,25	3	0,3
ERV05055125	5,5	10	125	3,75	0,25	3	0,3
ERV05055200	5,5	10	200	3,75	0,25	3	0,3

REF	d1	d2	L	B	C	K	R
ERV05060125	6	12	125	4	0,5	5	0,5
ERV05060200	6	12	200	4	0,5	5	0,5
ERV05062125	6,2	12	125	4,1	0,5	5	0,5
ERV05062200	6,2	12	200	4,1	0,5	5	0,5
ERV05065125	6,5	12	125	4,25	0,5	5	0,5
ERV05065200	6,5	12	200	4,25	0,5	5	0,5
ERV05070125	7	12	125	4,5	0,5	5	0,5
ERV05070200	7	12	200	4,5	0,5	5	0,5
ERV05080125	8	14	125	5	0,5	5	0,5
ERV05080200	8	14	200	5	0,5	5	0,5
ERV05082125	8,2	14	125	5,1	0,5	5	0,5
ERV05082200	8,2	14	200	5,1	0,5	5	0,5
ERV05085125	8,5	14	125	5,25	0,5	5	0,5
ERV05085200	8,5	14	200	5,25	0,5	5	0,5
ERV05090125	9	14	125	5,5	0,5	5	0,5
ERV05090200	9	14	200	5,5	0,5	5	0,5
ERV05100125	10	16	125	6	0,5	5	0,5
ERV05100200	10	16	200	6	0,5	5	0,5
ERV05102125	10,2	16	125	6,1	0,5	5	0,5
ERV05102200	10,2	16	200	6,1	0,5	5	0,5
ERV05105125	10,5	16	125	6,25	0,5	5	0,5
ERV05105200	10,5	16	200	6,25	0,5	5	0,5
ERV05110125	11	16	125	6,5	0,5	5	0,5
ERV05110200	11	16	200	6,5	0,5	5	0,5
ERV05115125	11,5	16	125	6,75	0,5	5	0,5
ERV05115200	11,5	16	200	6,75	0,5	5	0,5
ERV05120125	12	18	125	7	0,5	7	0,8
ERV05120200	12	18	200	7	0,5	7	0,8
ERV05125125	12,5	18	125	7,25	0,5	7	0,8
ERV05125200	12,5	18	200	7,25	0,5	7	0,8
ERV05140125	14	22	125	8,5	0,5	7	0,8
ERV05140200	14	22	200	8,5	0,5	7	0,8
ERV05160125	16	22	125	9,5	0,5	7	0,8
ERV05160200	16	22	200	9,5	0,5	7	0,8

CAD reference point

RETENUES

RETENUE POUR GOUPILLE INCLINÉE
F3060

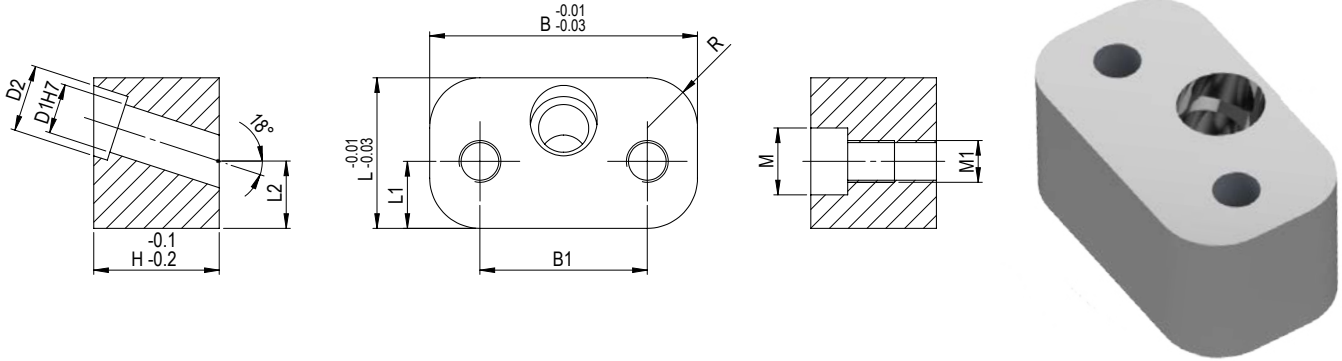
 Mat.: 1.2312
 ≈ 1080 N/mm²

REF	D1	D2	L	L1	L2	B	B1	H	M	M1	R
F30600618	6	8	18	8	8	32	20	12	M4	M5	6
F30600822	8	10	22	9	9	36	22	14	M5	M6	8
F30601018	10	12	18	8	6,8	40	24	18	M6	M8	8
F30601026	10	12	26	8,5	10	40	24	18	M6	M8	10
F30601223	12	15	23	10	8,5	40	26	24	M6	M8	10
F30601230	12	15	30	10	11	40	26	24	M6	M8	10
F30601426	14	17	26	10	9,45	44	28	28	M6	M8	10
F30601434	14	17	34	12	12	44	28	28	M6	M8	10
F30601630	16	19	30	12	11	52	34	32	M8	M10	12
F30601638	16	19	38	14	13	52	34	32	M8	M10	12
F30601833	18	21	33	12	12	54	36	36	M8	M10	12
F30601842	18	21	42	16	15	54	36	36	M8	M10	12
F30602036	20	23	36	12	13	56	38	40	M8	M10	12
F30602046	20	23	46	18	17	56	38	40	M8	M10	12
F30602240	22	25	40	12	14,8	62	42	44	M8	M10	12
F30602250	22	25	50	20	19	62	42	44	M8	M10	12
F30602442	24	27	42	12	15,3	66	44	46	M10	M12	12
F30602452	24	27	52	22	19	66	44	46	M10	M12	12
F30603062	30	35	62	24	22	74	52	56	M10	M12	16

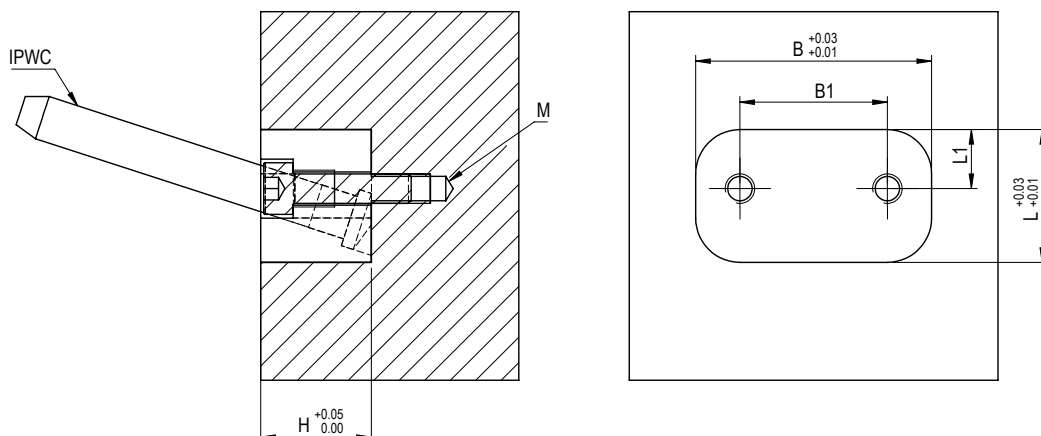

CAD reference point

CLAVETTE AVEC PLAQUE D'USURE

F3024

Mat: 1.2312
 ≈ 1080 N/mm²

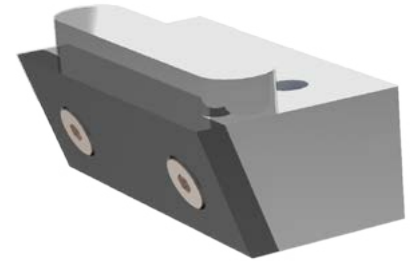
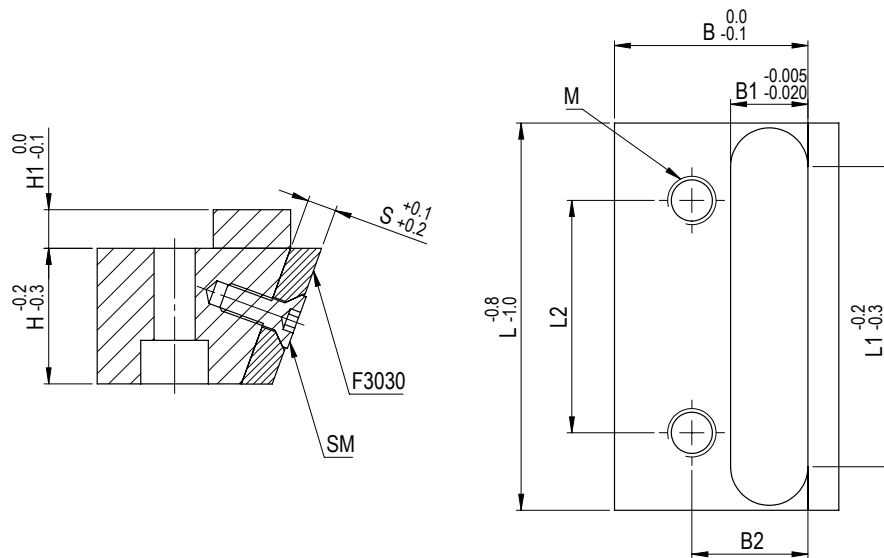

REF	H	L	L1	L2	M	M1	M2	B	B1	B2	H1	S
F302411020	11	20	10	-	M6	M4	M6	18	8	13	5	4
F302411028	11	28	18	-	M6	M4	M6	18	8	13	5	4
F302411040	11	40	30	24	M6	M4	M6	18	8	13	5	4
F302411056	11	56	46	34	M6	M4	M6	18	8	13	5	4
F302415020	15	20	8	-	M8	M6	M8	22	10	15	6	4
F302415028	15	28	16	-	M8	M6	M8	22	10	15	6	4
F302415040	15	40	28	24	M8	M6	M8	22	10	15	6	4
F302415056	15	56	44	32	M8	M6	M8	22	10	15	6	4
F302419024	19	24	10	-	M8	M6	M8	28	12	18	6	4
F302419036	19	36	22	-	M8	M6	M8	28	12	18	6	4
F302419040	19	40	26	-	M8	M6	M8	28	12	18	6	4
F302419050	19	50	36	32	M8	M6	M8	28	12	18	6	4
F302419060	19	60	46	36	M8	M6	M8	28	12	18	6	4
F302419072	19	72	58	44	M8	M6	M8	28	12	18	6	4
F302424024	24	24	10	-	M10	M8	M10	32	12	20	6	4
F302424036	24	36	22	-	M10	M8	M10	32	12	20	6	4
F302424040	24	40	26	-	M10	M8	M10	32	12	20	6	4
F302424050	24	50	36	30	M10	M8	M10	32	12	20	6	4
F302424060	24	60	46	36	M10	M8	M10	32	12	20	6	4
F302424072	24	72	58	44	M10	M8	M10	32	12	20	6	4
F302424080	24	80	66	48	M10	M8	M10	32	12	20	6	4
F302428040	28	40	22	-	M10	M8	M10	40	16	24	8	6
F302428050	28	50	32	26	M10	M8	M10	40	16	24	8	6
F302428060	28	60	42	36	M10	M8	M10	40	16	24	8	6
F302428080	28	80	62	48	M10	M8	M10	40	16	24	8	6
F302428100	28	100	82	64	M10	M8	M10	40	16	24	8	6
F302428120	28	120	102	74	M10	M8	M10	40	16	24	8	6
F302431032	31	32	14	-	M10	M8	M10	40	16	24	8	6
F302431040	31	40	22	-	M10	M8	M10	40	16	24	8	6
F302431046	31	46	28	24	M10	M8	M10	40	16	24	8	6

REF	H	L	L1	L2	M	M1	M2	B	B1	B2	H1	S
F302431050	31	50	32	26	M10	M8	M10	40	16	24	8	6
F302431060	31	60	42	36	M10	M8	M10	40	16	24	8	6
F302431064	31	64	46	40	M10	M8	M10	40	16	24	8	6
F302431080	31	80	62	48	M10	M8	M10	40	16	24	8	6
F302431086	31	86	68	52	M10	M8	M10	40	16	24	8	6
F302431100	31	100	82	64	M10	M8	M10	40	16	24	8	6
F302439040	39	40	22	-	M12	M10	M12	50	16	26	8	6
F302439056	39	56	38	32	M12	M10	M12	50	16	26	8	6
F302439080	39	80	62	52	M12	M10	M12	50	16	26	8	6
F302439112	39	112	94	68	M12	M10	M12	50	16	26	8	6
F302449040	49	40	18	-	M16	M12	M16	63	20	32	10	6
F302449050	49	50	28	-	M16	M12	M16	63	20	32	10	6
F302449060	49	60	38	32	M16	M12	M16	63	20	32	10	6
F302449072	49	72	50	40	M16	M12	M16	63	20	32	10	6
F302449080	49	80	58	46	M16	M12	M16	63	20	32	10	6
F302449100	49	100	78	64	M16	M12	M16	63	20	32	10	6
F302449120	49	120	98	74	M16	M12	M16	63	20	32	10	6
F302449140	49	140	118	84	M16	M12	M16	63	20	32	10	6
F302460040	60	40	18	-	M16	M12	M16	70	20	36	10	6
F302460050	60	50	28	-	M16	M12	M16	70	20	36	10	6
F302460060	60	60	38	32	M16	M12	M16	70	20	36	10	6
F302460080	60	80	58	46	M16	M12	M16	70	20	36	10	6
F302460100	60	100	78	64	M16	M12	M16	70	20	36	10	6
F302460120	60	120	98	74	M16	M12	M16	70	20	36	10	6
F302475050	75	50	23	-	M16	M12	M16	80	25	42	12	6
F302475060	75	60	33	32	M16	M12	M16	80	25	42	12	6
F302475080	75	80	53	46	M16	M12	M16	80	25	42	12	6
F302475100	75	100	73	64	M16	M12	M16	80	25	42	12	6
F302475120	75	120	93	74	M16	M12	M16	80	25	42	12	6

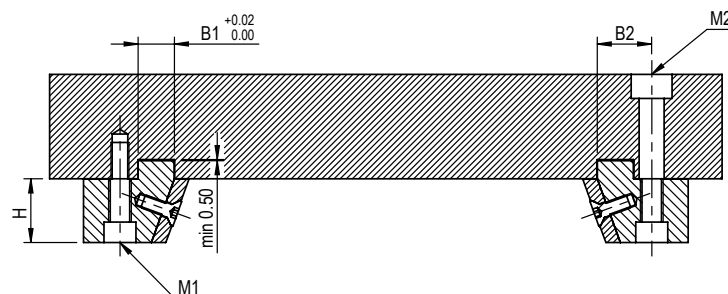

CAD reference point

BAGUES DE CENTRAGE

BAGUE DE CENTRAGE AVEC COLLET ET TROUS DE VIS
F1377

Mat.: 1.0503 (1.1730)

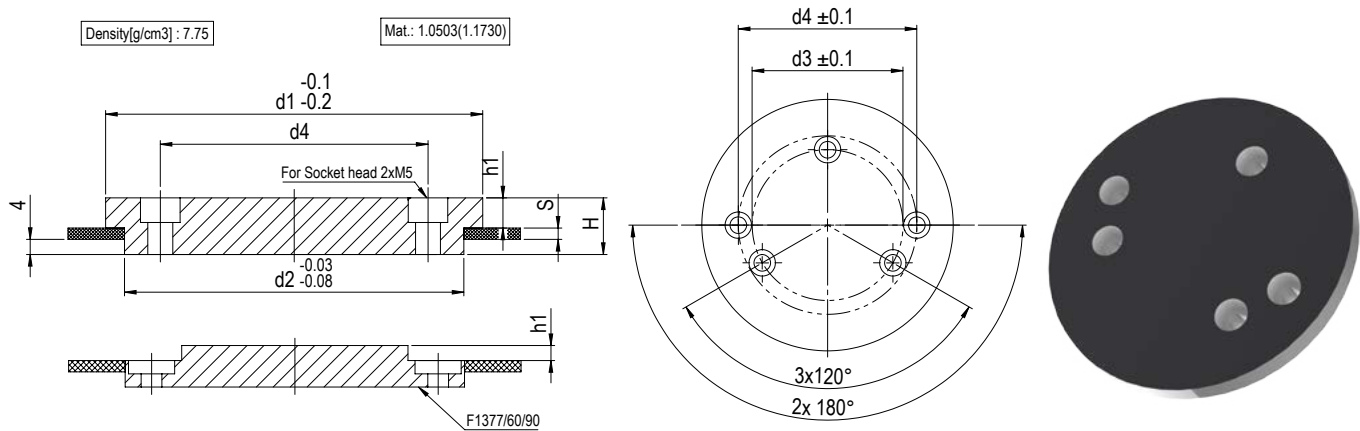

REF	d1	d2	H	S	d3*	d4**	h1
F137709006012	90	60	12	-	N/A	76	8
F137709006018	90	60	18	6	N/A	76	8
F137706009008	60	90	8	-	N/A	48	4
F137706009014	60	90	14	6	N/A	76	4
F137710009012	100	90	12	-	78	82	8
F137710009018	100	90	18	6	78	82	8
F137711009012	110	90	12	-	78	98	8
F137711009018	110	90	18	6	78	98	8
F137711009020	110	90	20	8	78	98	8
F137712009012	120	90	12	-	78	104	8
F137712009018	120	90	18	6	78	104	8
F137712009020	120	90	20	8	78	104	8
F137712509012	125	90	12	-	78	104	8
F137712509018	125	90	18	6	78	104	8
F137712509020	125	90	20	8	78	104	8

REF	d1	d2	H	S	d3*	d4**	h1
F137712509030	125	90	30	8	N/A	104	18
F137716009012	160	90	12	-	78	128	8
F137716009018	160	90	18	6	78	128	8
F137716009020	160	90	20	8	78	128	8
F137716009030	160	90	30	8	N/A	128	18
F137717509012	175	90	12	-	78	128	8
F137717509018	175	90	18	6	78	128	8
F137717509020	175	90	20	8	78	128	8
F137717516020	175	160	20	6	N/A	144	10
F137717516022	175	160	22	8	N/A	144	10
F137720016014	200	160	14	-	N/A	144	10
F137720016022	200	160	22	8	N/A	144	10
F137725016014	250	160	14	-	N/A	144	10
F137725016022	250	160	22	8	N/A	144	10

Notes :

- *) d3 = diamètre d'entraxe pour 3 trous
- **) d4 = diamètre d'entraxe pour 2 trous

VIS ÉPAULÉE **GM**

Mat: 1.7131
≈ 60HRC

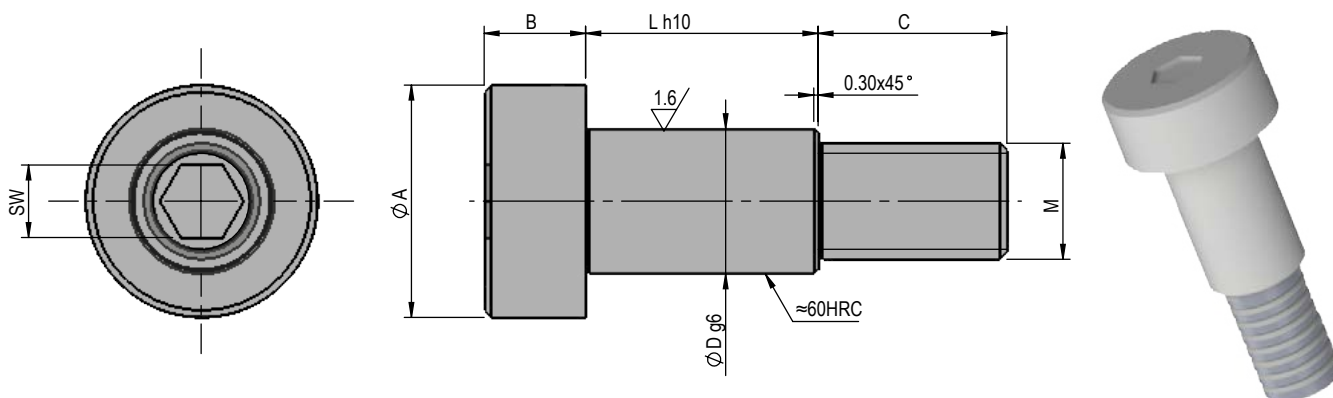

REF	D	L	C	M	B	A	SW
GM10016	10	16	13	M8	7	16	5
GM10020	10	20	13	M8	7	16	5
GM10025	10	25	13	M8	7	16	5
GM10030	10	30	13	M8	7	16	5
GM10040	10	40	13	M8	7	16	5
GM10050	10	50	13	M8	7	16	5
GM10060	10	60	13	M8	7	16	5
GM10070	10	70	13	M8	7	16	5
GM10080	10	80	13	M8	7	16	5
GM10090	10	90	13	M8	7	16	5
GM10100	10	100	13	M8	7	16	5
GM12020	12	20	16	M10	9	18	6
GM12025	12	25	16	M10	9	18	6
GM12030	12	30	16	M10	9	18	6
GM12040	12	40	16	M10	9	18	6
GM12050	12	50	16	M10	9	18	6
GM12060	12	60	16	M10	9	18	6
GM12070	12	70	16	M10	9	18	6
GM12080	12	80	16	M10	9	18	6
GM12090	12	90	16	M10	9	18	6
GM12100	12	100	16	M10	9	18	6
GM12120	12	120	16	M10	9	18	6

REF	D	L	C	M	B	A	SW
GM14025	14	25	16	M10	9	21	6
GM14030	14	30	16	M10	9	21	6
GM14040	14	40	16	M10	9	21	6
GM14050	14	50	16	M10	9	21	6
GM14060	14	60	16	M10	9	21	6
GM14070	14	70	16	M10	9	21	6
GM14080	14	80	16	M10	9	21	6
GM14090	14	90	16	M10	9	21	6
GM14100	14	100	16	M10	9	21	6
GM14120	14	120	16	M10	9	21	6
GM14140	14	140	16	M10	9	21	6
GM18030	18	30	18	M12	11	27	8
GM18040	18	40	18	M12	11	27	8
GM18050	18	50	18	M12	11	27	8
GM18060	18	60	18	M12	11	27	8
GM18070	18	70	18	M12	11	27	8
GM18080	18	80	18	M12	11	27	8
GM18090	18	90	18	M12	11	27	8
GM18100	18	100	18	M12	11	27	8
GM18120	18	120	18	M12	11	27	8
GM18140	18	140	18	M12	11	27	8

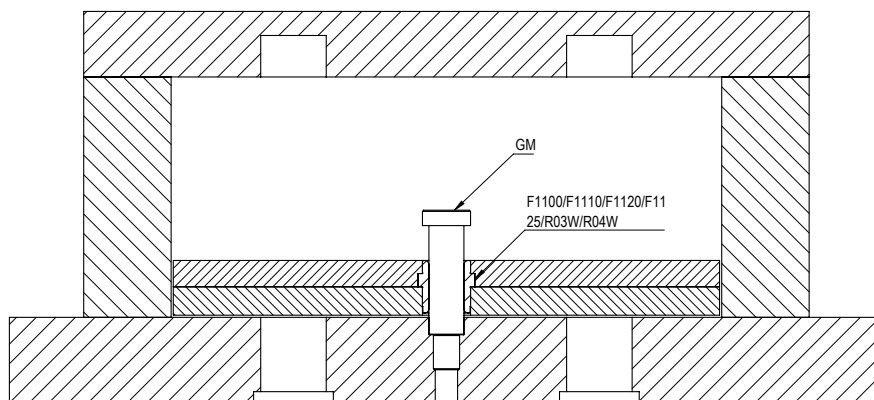

CAD reference point



eSTORE
store.milacron.com
Available Online
24/7

ÉJECTION DE
MOULE



COMPOSANTS
DE MOULE



COMPOSANTS
D'APPLICATION
TECHNIQUE



REFROIDISSEMENT
DE MOULE



AUXILLIAIRES

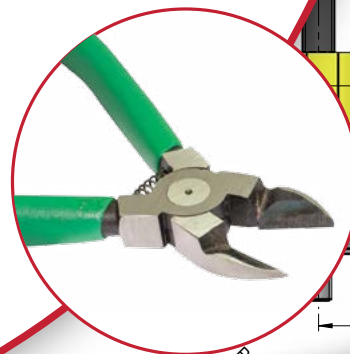

Schaliënhoevedreef 20-D
(Mechelen Campus)
Mechelen | BE-2800 | Belgium
dme_uk@dme.net
+44 2071 3300 37

