

LIFETIME
ROLLER LOCKS

DME LIFETIME ROLLER LOCKS

Advanced Alignment Technologies by DME

To take full advantage of lean manufacturing practices and increase productivity today's molders demand high reliability of equipment and tooling. Alignment of the mold during the process is critical to the reliability and the achievement of high levels of O.E.E (Overall Equipment Effectiveness). This is especially challenging over the life-cycle of the tool as thermal expansion and general tooling precision can cause movement of the plates and effect molding performance.

With poor alignment; part quality can suffer, cycle times can be reduced, unnecessary production downtime can occur and the tool itself can be damaged. All of these problems can minimized and profitability maximized using an interlock that has been tried and tested and, designed for the best possible lifetime performance.



DME LT-Series LifeTime Roller Locks

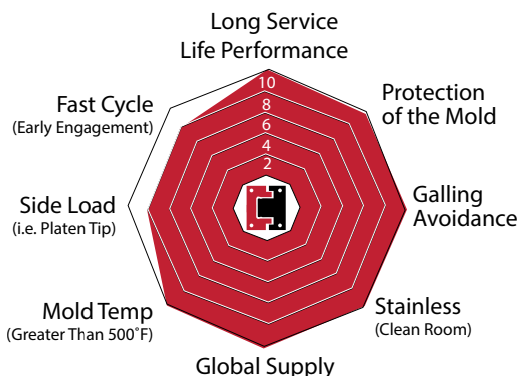

Competitor Side Locks

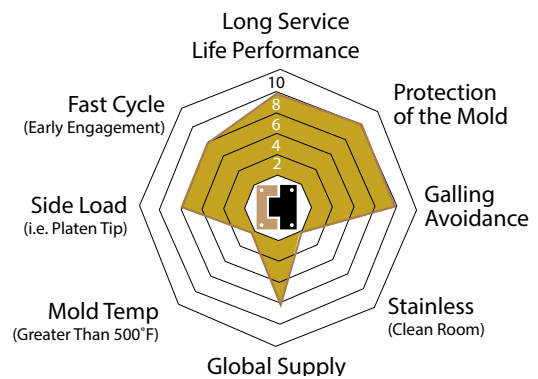

CHALLENGES OF ALIGNMENT

Heat Variation

Heat variations can cause misalignment of the mold over time. Managing temperature changes in stationary and movable mold halves is critical:

1. Mold cooling, including the temperature differential between mold halves.

- Steel grows approximately 0.0000065 inch for every degree Fahrenheit of temperature differential. When A and B halves vary by as little as 20 deg F and the mold is 30 inches long, the difference in plate lengths is about 0.004 inch..... enough to start wearing of the alignment components. To extend mold life, try to keep the all of the mold plates (mold halves) at a consistent temperature.

2. Hot runner system heating.

- Since these systems are driven by electric heaters, they can be a major contributor to mold temperature variations if proper cooling is overlooked.

3. Insulator plates.

- As production begins, insulator plates (top and bottom of the mold) will create a temporarily controlled closed environment. But any heat generated within the mold will eventually migrate through the insulating materials into the press platens and affect the alignment of the mold halves.

PARTING LINE ALIGNMENT

Improper mold alignment can cause dimensional problems, flash, damaged components, or even a mold that won't run anymore.

Initial Engagement

Interlocks must be able to allow for interference/angled engagement as the movable platen tends to lean forward and sag out of alignment due to mold weight and the toggle function. Also the cavity/core alignment is influenced by the quality/condition and location of guide pins and bushings, if these components are worn or out of place the alignment of the movable and stationary halves will be off.



DME LifeTime Side Locks

vs. Standard Side Locks

Five degree =

0,457mm interference fit

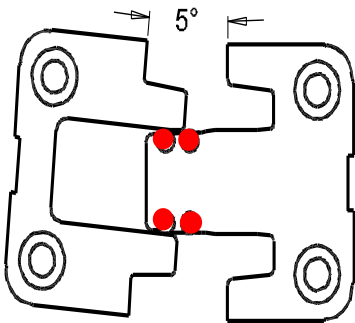

One Tenth Degree =

0,056mm Interference fit

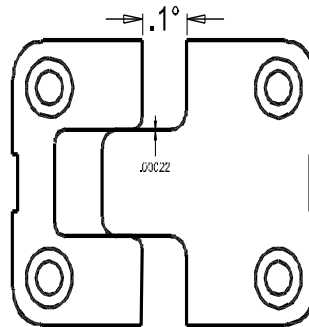

Two degree =

0,148mm interference fit

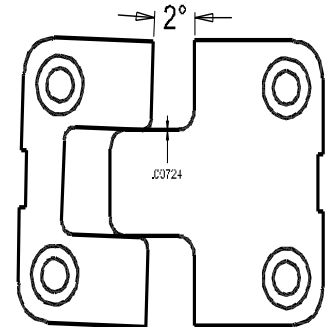

Initial Engagement

Interlocks must be able to allow for interference/angled engagement as the movable platen tends to lean forward and sag out of alignment due to mold weight and the toggle function. Also the cavity/core alignment is influenced by the quality/condition and location of guide pins and bushings, if these components are worn or out of place the alignment of the movable and stationary halves will be off. These components provide the primary alignment of the mold halves.

Early Alignment for Precision Shutoffs

Interlocks align mold halves to protect precision tapered shut off inserts from being damaged. This is especially true with cross over telescoping cavity and core inserts.

Final Lockup Holding Strength

Interlocks provide constraints to counter the pressure produced during injection ensuring the A and B plate do not shift which results in a constant molded part thickness and matched parting lines.

THE BIG 3 REASONS FOR LIFETIME LOCK SUCCESS

1. Hartmetallrollen können das Festfressen beim ersten Eingreifen reduzieren oder beseitigen

Eine bewegliche Platte neigt sich gewöhnlich nach vorne, was durch das Formengewicht und die Kippwirkung zur Fehlausrichtung führen kann



2. Early Alignment for Precision Shutoffs

Interlock aligns mold halves to protect precision tapered shut off inserts from being damaged. This is especially true with cross over telescoping inserts from one half to the other half

3. Triple & Penta-Locking Configurations (Patented)

Constrains counter-pressure of the injection to ensure constant molded part thickness and matched parting lines, resulting in the most precise location and holding power on final lock-up in the industry.

Patent No. US 6,981,858 B2

Patent No. US 6,558,145 B2

LifeLocks 3"
Penta-Lock Design

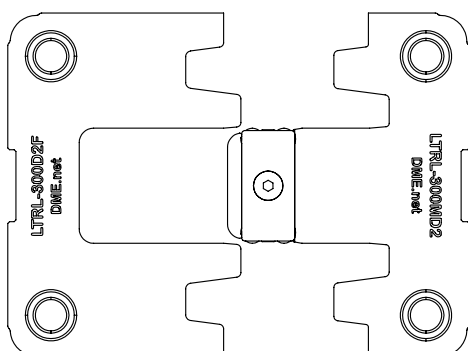

LifeLocks 1-2"
Triple Lock Design

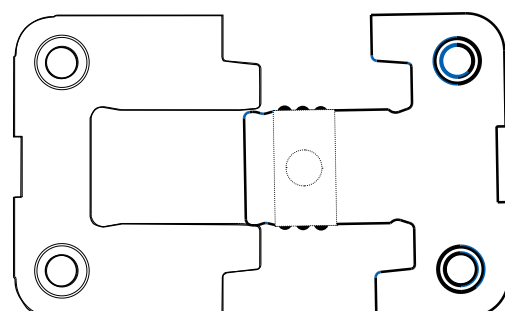

3 BASE MATERIALS TO FIT YOUR APPLICATION

Our standard lock made of D2 **outperforms the competition in 3 ways**, Longer lead for early engagement and protect for cross over shut off, carbide rollers reduce friction and ease early engagement when the mold halves come together, the triple locking design provides more bearing surface when the locks are fully engaged.

Our DC53 locks have all the same great features as standard locks with the added benefit to **withstand the demands of running high temperatures (700°F) required for molding engineered resins**. Competitor locks will anneal and prematurely wear due to the higher heat. DME's DC53 lock will withstand this type off application with long life performance.

Our 440C stainless-steel locks have the same long lasting performance design features as our standard lock and have been developed to meet the requirements of clean room and packaging applications.

PERFORMANCE TESTED

Lab Testing

- Millions of Cycles
- Virtually No Wear
- Grease on rollers were still evident after 200,000 cycles

Field Production Testing

- Minimal wear after a million cycles or 14 months of fast cycle production
- No locks have seized or fractured
- Locks did not need position rotation

YOUR BENEFITS

Precision Alignment Combing the Technology of:

- Straight
- Tapered
- Carbide Roller Bearing
- Made in 3 materials to fit your application needs.

Advantages

- Non-binding low friction alignment
- 30% earlier aligned engagement
- Final taper lock up strength
- Full Interchangeability male and female
- Retrofittable to industry standard foot-print, no additional machining required

ALIGN YOUR PRIORITIES WITH THE LIFETIME LOCK ADVANTAGE

1. DME Carbide Rollers glide into position vs. conventional lock surfaces

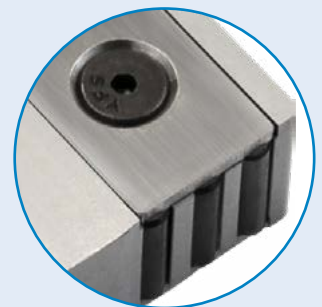

2. Elongated male section allows earlier engagement and more forgiving entrance angles.



3. Two additional locking features insure precise alignment

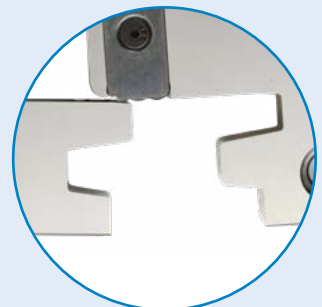

PRODUCT SPECIFICATIONS

DME LifeTime Locks: Penta-Lock Configuration

3 INCH LOCKS

Penta-Lock Is Ideal For Molds With Increased Closing Force & Higher Injection Pressures To Ensure A Precision Lock Up At Final Close.

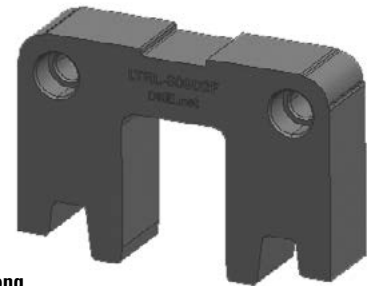
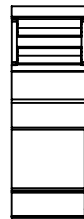
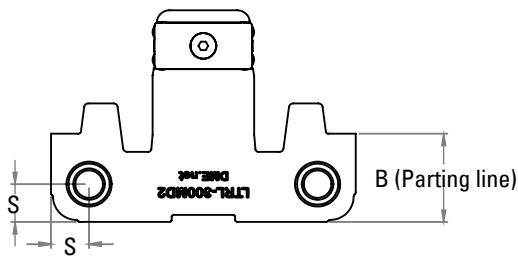
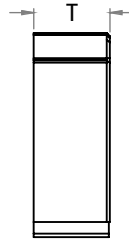
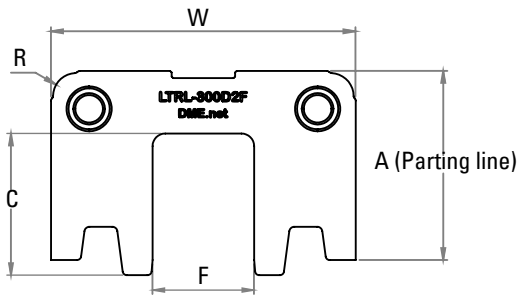

Extended Long Engagement To Protect Cross Over Shutoff

Carbide Rollers To Help Align Mold Haves

Interlacing Locking Condition

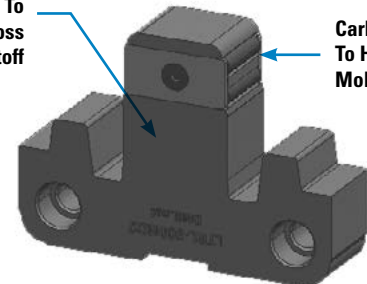

REF			STEEL TYPE	Dimensions given in inches.								SHCS SIZE
Standard Assembly (1 MALE, 1 FEMALE)	Shuttle Assembly (1 MALE, 1 FEMALE)	FEMALE ONLY		W	A	B	C	F	T	R	S	
LTRL-300D2	LTRL-300D2-SH	LTRL-300D2F	D2	3.00	1.875	0.875	1.375	1.000	0.750	0.240	0.375	1/4-20
LTRL-300HT	LTRL-300HT-SH	LTRL-300HTF	DC-53	3.00	1.875	0.875	1.375	1.000	0.750	0.240	0.375	1/4-20
LTRL-300SS	LTRL-300SS-SH	LTRL-300SSF	440C SS	3.00	1.875	0.875	1.375	1.000	0.750	0.240	0.375	1/4-20

PRODUCT SPECIFICATIONS

DME LifeTime Locks: Triple Lock Configuration

LOCK SIZE 1-2 INCHES

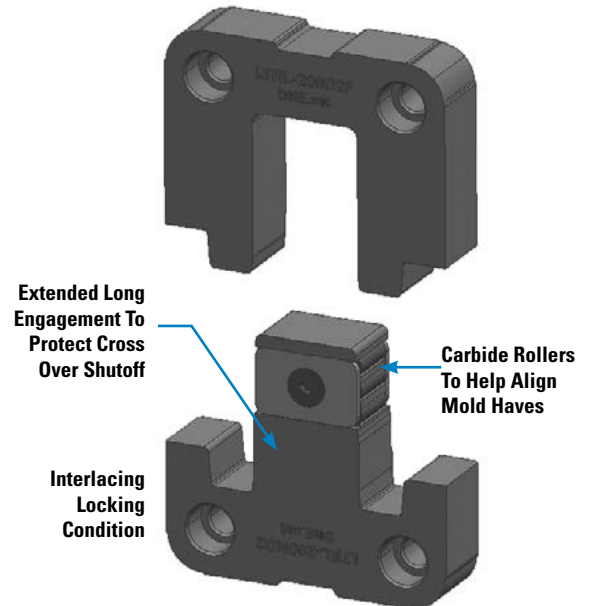
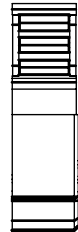
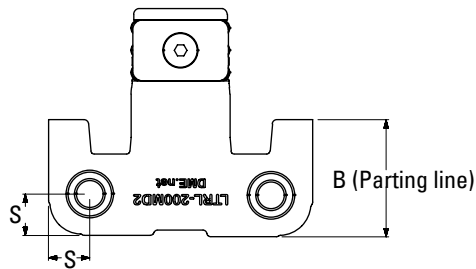
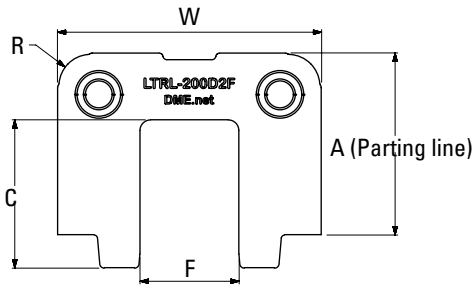

REF			STEEL TYPE	Dimensions given in inches.								SHCS SIZE
Standard Assembly (1 MALE, 1 FEMALE)	Shuttle Assembly (1 MALE, 1 FEMALE)	FEMALE ONLY		W	A	B	C	F	T	R	S	
LTRL-100D2	LTRL-100D2-SH	LTRL-100D2F	D2	1.00	1.125	0.875	0.665	0.630	0.375	0.177	0.250	10-32
LTRL-100HT	LTRL-100HT-SH	LTRL-100HTF	DC-53	1.00	1.125	0.875	0.665	0.630	0.375	0.177	0.250	10-32
LTRL-100SS	LTRL-100SS-SH	LTRL-100SSF	440C SS	1.00	1.125	0.875	0.665	0.630	0.375	0.177	0.250	10-32
LTRL-150D2	LTRL-150D2-SH	LTRL-150D2F	D2	1.50	1.175	0.875	0.867	0.560	0.375	0.177	0.250	8-32
LTRL-150HT	LTRL-150HT-SH	LTRL-150HTF	DC-53	1.50	1.175	0.875	0.867	0.560	0.375	0.177	0.250	8-32
LTRL-150SS	LTRL-150SS-SH	LTRL-150SSF	440C SS	1.50	1.175	0.875	0.867	0.560	0.375	0.177	0.250	8-32
LTRL-200D2	LTRL-200D2-SH	LTRL-200D2F	D2	2.00	1.375	0.875	1.089	0.750	0.375	0.240	0.313	10-32
LTRL-200HT	LTRL-200HT-SH	LTRL-200HTF	DC-53	2.00	1.375	0.875	1.089	0.750	0.375	0.240	0.250	10-32
LTRL-200SS	LTRL-200SS-SH	LTRL-200SSF	440C SS	2.00	1.375	0.875	1.089	0.750	0.375	0.240	0.250	10-32



FROM PELLET TO PART
YOUR PARTNER FOR PRODUCTIVITY AND SUSTAINABILITY

Order
Online



eSTORE
store.dme.net

Available
Online 24/7



Or Call Our Customer Care Team

AT
P: 800 301 60
F: 800 401 020
dme_oesterreich@dme.net

DE
P: 800 664 82 50 | +49 (0) 2351 437 0
F: 800 664 82 51 | +49 (0) 2351 437 220
dme_normalien@dme.net

IT
P: 800 089 734
F: 800 089 735
dme_italy@dme.net

SK
P: 800 142 451 | +420 572 151 754
F: 800 142 450 | +420 571 611 996
dme_cz@dme.net

BE
P: +32 (0) 15 28 87 30
F: +32 (0) 15 40 51 17
dme_benelux@dme.net

ES
P: 900 900 342
F: 900 900 343
dme_iberia@dme.net

NL
P: +31 (0) 20 654 5571
F: +31 (0) 20 654 5572
dme_benelux@dme.net

UK
P: +44 2071 3300 37
F: +44 2071 3300 36
dme_uk@dme.net

CH
P: +41 0848 567 364
F: +41 0848 567 365
dme_schweiz@dme.net

FR
P: +33 1 49 93 92 23
F: +33 1 49 93 92 22
dme_france@dme.net

PL
P: +800 331 1312 | +32 15 21 50 92
F: +800 331 1313 | +32 15 40 51 92
dme_polska@dme.net

Other countries
P: +32 15 28 87 30
F: +32 15 40 51 17
dme_export@dme.net

CZ
P: 800 142 451 | +420 572 151 754
F: 800 142 450 | +420 571 611 996
dme_cz@dme.net

HU
P: 0680 205 003 | +32 15 28 87 30
F: +32 15 40 51 17
dme_hungary@dme.net

PT
P: 800 207 900
F: 800 207 901
dme_iberia@dme.net