

FLOWMETERS

SMARTFLOW® TRACER[®] VM Base Flowmeters

This is not your standard flowmeter! The TRACER[®] VM raises the bar by reporting Temperature and Flow rates electronically to aid in cooling and process efficiency.



The Tracer[®] VM Flowmeter is a non-display meter that reports flow rates and temperature via voltage signals for connection to data acquisition system or Bluetooth Interface. The TRACER[®] VM is designed for use in industrial water applications such as injection mold cooling and pump monitoring. The flowmeter uses Vortex sensor technology that is highly accurate and repeatable without any moving parts. Connection to the process is made using standard pipe threads in NPT or BSP from 3/8" through 1-1/2". The flowmeter body materials are corrosion-resistant and can be ordered in brass, nylon, anodized aluminum or stainless steel. These options are based on inlet/thread size, see next page for the complete details.

Electrical Connection

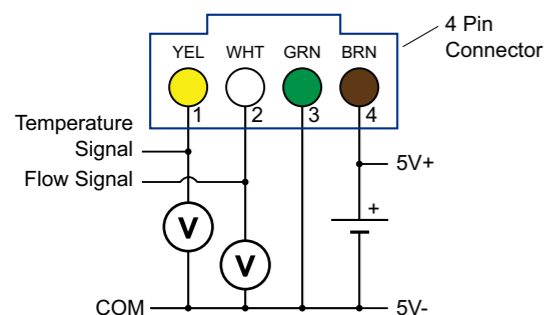

Pin	Description	Color
1	Temperature Signal*	Yellow
2	Flow Signal*	White
3	Common (0V)	Green
4	Power Supply (+5VDC)	Brown

*relative to Pin 3

Benefits

- No moving parts for reliable operation
- Flow and Temperature Sensors in one unit for compact installation
- Quick temperature response from direct media contact
- Economical and versatile construction with corrosion-resistant materials

Materials

Sensing Element Silicone-Based MEMS Sensor
 Seal (sensor to housing) EPDM
 Insert PPA 40 GF
 3/8" & 1/2" Body Size Glass Filled Nylon Flow Body
 Brass or Nylon End Caps
 3/4" thru 1-1/2" Body Size Anodized Aluminum
 or Stainless Steel Flow Body
 Cable 2.9M (9.5ft) 4-conductor for power
 and output, ends stripped

Power Supply

- 5VDC
- Separated from hazardous live circuit by double or reinforced insulation
- Suggested current limit 50-100mA

Specifications

Flow Ranges and Connection Sizes

Flow Range	Connection Size
1 to 15 LPM (.3 to 4 GPM)	3/8" or 1/2"
2 to 40 LPM (.5 to 10.6 GPM)	3/8" or 1/2"
5 to 100 LPM (1.3 to 26.4 GPM)	3/4" or 1"
10 to 200 LPM (2.6 to 52.8 GPM)	1" or 1-1/2"

Flow Accuracy +/-1.5% of Full Scale
 Temperature Range 0°C to 120°C (32°F to 248°F)
 Temperature Accuracy +/-0.5°C
 Operating Pressure 10.3 bar max (150 psi max)

Power

Power Supply 5 VDC +/-5% (external)
 Output Signals Ratiometric
 Flow Signals 0.5 to 3.5V (zero at .35V)
 Temperature Signal 0.5 - 4.1V
 Power Consumption <50mW
 Load Impedance >10kΩ

How to order

VM	3	-	B	-	15	-	B
Body Size							
3/8" NPT	3						
3/8" BSPP	3B		B or N		15H		
1/2" NPT	4				40H		
1/2" BSPP	4B						
3/4" NPT	6		AL or SS		100H		
3/4" BSPP	6B						
1" NPT	8		AL or SS		100H		
1" BSPP	8B				200H		
1-1/2" NPT	12		AL or SS		200H		
1-1/2" BSPP	12B						

Body Material

Glass-Filled Nylon with Brass End Caps
 Nylon End Caps (3/8" and 1/2" only)
 Anodized Aluminum
 Stainless Steel Body (3/4" and larger only)

Flow Range

1 to 15 LPM (.3 to 4 GPM)	15H
2 to 40 LPM (.5 to 10.6 GPM)	40H
5 to 100 LPM (1.3 to 26.4 GPM)	100H
10 to 200 LPM (2.6 to 52.8 GPM)	200H

When using with RJG eDart IA-2 module
 Add line item:
 Part no. CONN-LBG-4-F
 Description: 4-pin Connector added to cable

ORDER EXAMPLE

VM3BB15HB

3/8" or 1/2" Body Sizes (Nylon or Brass End Caps)

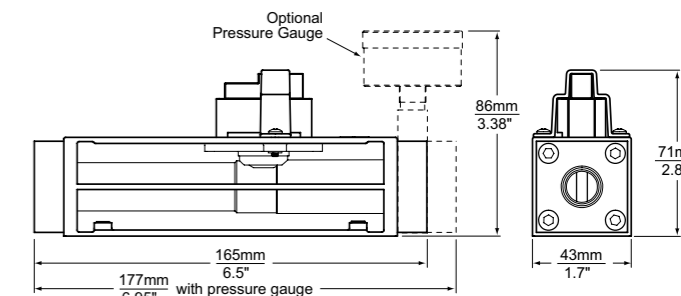

3/4" or 1-1/2" Body Sizes (Nylon or Brass End Caps)

Aluminum or Stainless Steel (pressure gauge not available with AL body)

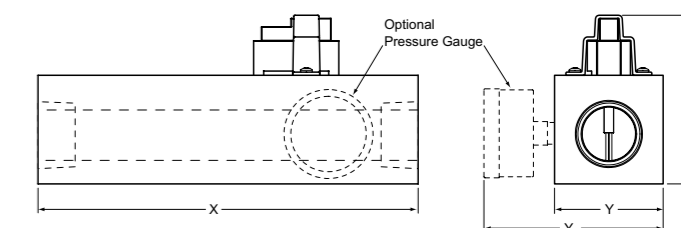

Dimensions (mm/inches)

Body Size	Flow	X	Y	Y ₁	Z
3/4", 5 to 100 LPM	5 to 100 LPM	178/7.0	45.7/1.8	77/3.1	74.2/2.9
1", 5 to 100 LPM		178/7.0	45.7/1.8	77/3.1	74.2/2.9
1" 10 to 200 LPM		178/7.0	51/2.0	84/3.3	79/3.1
1-1/2", 10 to 200 LPM		198/7.8	58/2.3	90/3.6	86/3.4

Directives

Flow sensors are in conformity with these Council directives on the approximation of the laws of the EC member states:

- Low Voltage Directive (2006/95/ED) Standards used: EN 61010-1:2001
- EMC Directive (2004/108/EC) Standards used: EN 61326-1:2006 and 61326-2-3:2006

Smartflow Vortex flow sensors fall under Article 3, 3 of PED Directive 97/23/EEC and are therefore not required to be CE-marked according to this directive.

SMARTFLOW® TRACER®_{VM} with Local or Remote USER INTERFACE

No more guessing or misreading confusing manual flow meters. The TRACER_{VM} USER INTERFACE provides flow rates, temperature, and Turbulent Flow in an easy to read digital display.



Tracer_{VM} Flowmeter with User Interface measures liquid flow rate and temperature while providing a selectable analog voltage and programmable switch. Tracer_{VM} Flowmeter with User Interface calculates BTU's per minute and incorporates FCI (Flow Characteristic Indicator) in support of Scientific CoolingSM principles. Vortex sensor technology is highly accurate and repeatable without moving parts. Flow reading is direction specific. Refer to the arrow on the body for correct flow direction for installation.

8 to 28VDC power source is required to supply the flowmeter. Sealed push-buttons configure the flowmeter and switching operations through user-friendly menus.

Separate analog outputs facilitate data collection of temperature and flow rates. The voltage outputs are user-selectable using on-screen menus: 0 to 5 Volts or 0 to 10 Volts.

FCI helps optimize systemic water usage. "TF" on the digital display signifies the presence of Turbulent Flow, or optimum cooling water efficiency. 0, 10, 20 or 30% glycol mix is supported in Turbulent Flow calculations. SPDT switch is programmable for one to four set points: low flow, high flow, low temperature, high temperature or turbulent flow condition. Set points may be turned on or off in any combination to signify an alarm state.

Totalizer function provides volume display from a user-selected start point. (Maximum value is approximately 42,949,000 liters or 11,338,000 gallons.)

English or Metric units for flow and temperature can be changed at any time.

New Reynolds Number Display provides instant turbulent flow information based on water temperature, flow rate, cooling line diameter and glycol content. See page 7 for turbulent flow and value curve information

Applications Tracer flowmeter is suitable for use in industrial water applications such as: injection mold cooling, die cast cooling, filter condition indication and more.

Tracer_{VM} Flowmeter with User Interface is ideally suited for connection to data acquisition systems. These systems give plastics injection molders real-time statistical process control. Annual calibration is recommended for best results. Flow sensor and user interface electronics are paired and must be used together once calibration is complete.

Remote User Interface may be mounted up to 2.9M (9.5ft) away from the Tracer_{VM} Base Model (sensor and flow body without display). Use the "R" designator in the model number for a completely new unit or order a stand-alone Remote User Interface to use with an existing Base Model.

Specifications

Flow Ranges and Accuracy		
Body Size	Range (LPM)	Range (GPM)
3/8" & 1/2"	1 to 15	.3 to 4
3/8" & 1/2"	2 to 40	.5 to 10.6
3/4" to 1"	5 to 100	1.3 to 26.4
1" to 1-1/2"	10 to 200	2.6 to 52.8

Flow Accuracy..... +/-1.5% of Full Scale
 Temperature Range 0°C to 120°C (32°F to 248°F)
 Temperature Accuracy +/-0.5°C
 Operating Pressure..... 10.3 bar max (150 psi max)

Power

Power Supply..... 8 to 28 VDC (external)
 Switch Rating..... 30 VDC/30VAC
 Flow and Temp Signals 0 to 5 or 0 to 10 VDC

Materials

Sensing Element Silicone-Based MEMS Sensor
 Seal (sensor to housing)..... EPDM
 Insert..... PPA 40 GF
 3/8" & 1/2" Body Size Glass Filled Nylon Flow Body
 Brass or Nylon End Caps
 3/4" thru 1-1/2" Body Size..... Anodized Aluminum
 or Stainless Steel Flow Body

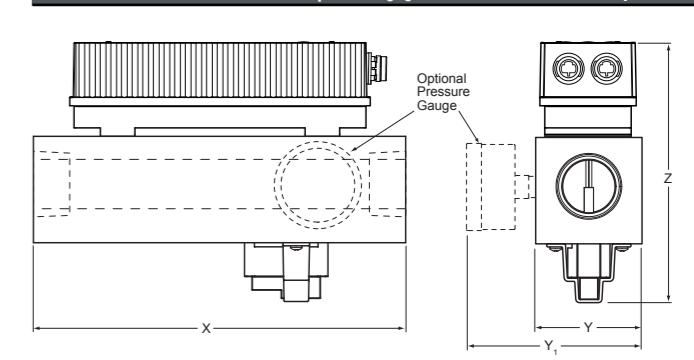
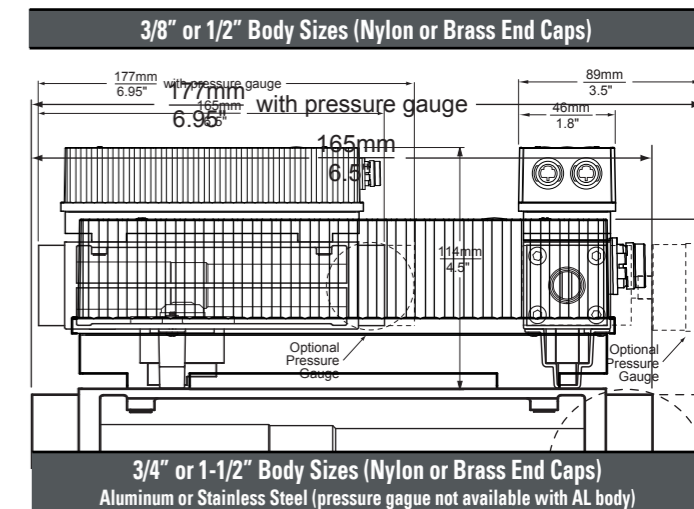

Dimensions (mm/inches)				
Body Size	X	Y	Y ₁	Z
3/4", 5 TO 100 LPM	178/7.0	45.7/1.8	77/3.1	117/4.6
1", 5 TO 100 LPM	178/7.0	45.7/1.8	77/3.1	117/4.6
1" 10 TO 200 LPM	178/7.0	51/2.0	84/3.3	122/4.8
1-1/2", 10 TO 200 LPM	198/7.8	58/2.3	90/3.6	130/5.1

Directives

Flow sensors are in conformity with these Council directives on the approximation of the laws of the EC member states:

- Low Voltage Directive (2006/95/ED) Standards used: EN 61010-1:2001
- EMC Directive (2004/108/EC) Standards used: EN 61326-1:2006 and 61326-2-3:2006

Smartflow Vortex flow sensors fall under Article 3, 3 of PED Directive 97/23/EEC and are therefore not required to be CE-marked according to this directive.

How to order

VM	3	-	B	-	15	-	L	ORDER EXAMPLE
Body Size								VM3BB15HB
3/8" NPT	3		B or N		15H 40H		User Interface L Local (display housing attached to flow body, standard) R Remote (display housing on mounting plate with cable connection to flow body) 2.9 (M)	
3/8" BSPP	3B							
1/2" NPT	4							
1/2" BSPP	4B							
3/4" NPT	6		AL or SS	100H				
3/4" BSPP	6B							
1" NPT	8		AL or SS	100H 200H				
1" BSPP	8B							
1-1/2" NPT	12		AL or SS	200H				
1-1/2" BSPP	12B							
Body Material				Flow Range				
Glass-Filled Nylon with Brass End Caps			B	15H	1 to 15 LPM (.3 to 4 GPM)			How to order Two part numbers are required to order. 1 - Choose the model number from this page 2 - Choose cable per below EFM-CBL-OPCA - Loose leads (standard, ends stripped) CBL-VMI-WWA - 120VAC power supply wall adapter EFM-CBL-OPC-0 - Cylindrical connectors for use with RJG IA1 module
Nylon End Caps (3/8" and 1/2" only)			N	40H	2 to 40 LPM (.5 to 10.6 GPM)			
Anodized Aluminum			AL	100H	5 to 100 LPM (1.3 to 26.4 GPM)			
Stainless Steel			SS	200H	10 to 200 LPM (2.6 to 52.8 GPM)			

Add user interface to existing Tracer_{VM} base model

User Interface can be added at the factory to customer-supplied Tracer_{VM} without local display. Two part numbers are required.

- 1 - Contact the factory for an RMA number
- 2- Local Interface, order part number VMUI-100
- 3- Choose cable per below
 - EFM-CBL-OPC - Loose leads (standard, ends stripped)
 - CBL-VMI-WWA - 120VAC power supply wall adapter
 - EFM-CBL-OPC-0 - Cylindrical connectors for use with RJG IA1 module



Turbulent Flow Basics

Turbulent water flow is much more efficient at removing heat in a cooling system than water flowing under laminar conditions. Once turbulent flow is achieved, increasing the flow rate does not significantly improve the cooling rate of the system. In molding applications, many mold operators try to maximize the flow of water through their cooling systems to ensure turbulent flow. Doing so increases energy costs for pumping more water than necessary through the system. This practice may also limit the amount of cooling water available for cooling additional molds on the same cooling system circuit. By insuring turbulent flow using FCI Technology, less water can be used in the molding process, saving precious resources.

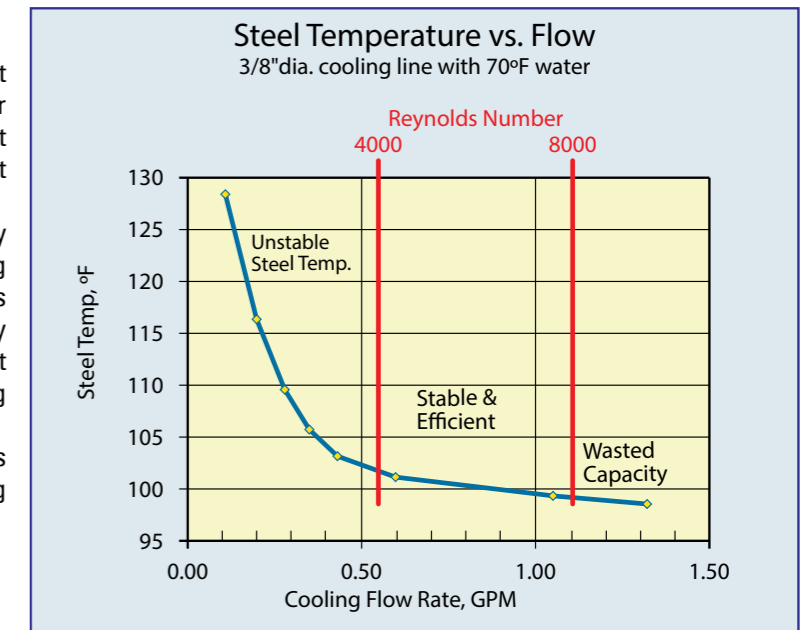

VM12BAL200HL

VM4BN40HR



Local User Interface

Remote User Interface

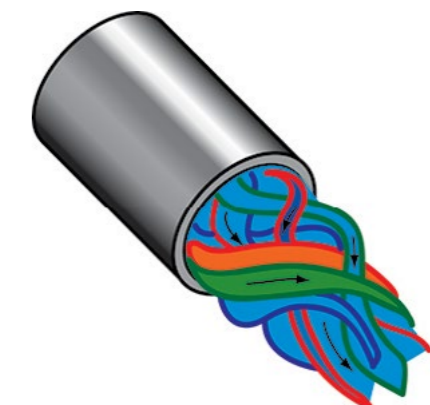
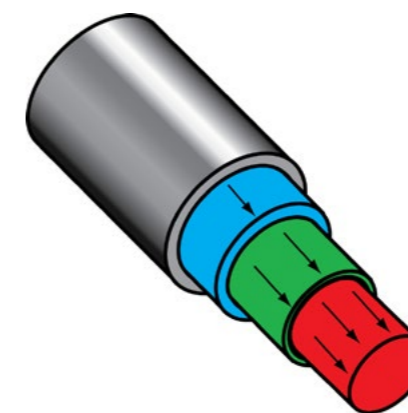

SMARTFLOW® TRACER_{VM}® BLUETOOTH INTERFACE

Step into the 21st century with the TRACER_{VM} Bluetooth interface. Operators are able to view real time cooling data via Bluetooth compatible devices.

Tracer_{VM} Bluetooth Interface collects, transmits and saves data from Tracer_{VM} Base flowmeters installed in injection mold cooling circuits. Flowmeters purchased separately are connected via cable to the Tracer_{VM} Bluetooth Interface. The Interface provides power to each flowmeter and receives voltage signals for temperature and flow. The Bluetooth Interface wirelessly transmits flow and temperature to display on a mobile device. Flow condition data log files can be created via app and saved on USB flash drive documenting the mold cooling water conditions. The Interface also communicates over Ethernet connection to PC software for network file storage and alerts. The files are easily read into database software for reference or analysis. Scientific Molders can use this data to confirm processing parameters and optimize cycle times and cooling water efficiency.

ITEM NUMBER
VMBT1100



Data Logger Software
(PC based for network file storage and alarm capabilities)



The Apple logo and iTunes are trademarks of Apple Inc., registered in the U.S. and other countries. Google Play and the Google Play logo are trademarks of Google Inc.

Tracer_{VM} Bluetooth Interface includes the Interface module and all software necessary to create cooling line log files.

Mobile app allows for creation of log files to be saved on Interface connected USB. The Ethernet port on the Interface connects to local network enabling log file creation, storage and process alerts.

Peripheral equipment such as PC, Mobile Device or flash drives are user provided. Input comes from Tracer_{VM} Base models.



Features and Benefits

- Transmits temperature and flow conditions in real time to mobile devices for process monitoring up to 20 meters away.
- Simplifies multiple Tracer_{VM} Base installations by providing power, ground and signal termination near the process.
- Gasketed, water-resistant plastic enclosure provides secure mounting in locations where occasional water spray is present.
- Housing mounting holes are integral for easy installation.
- Ethernet port connects the Interface to a local network for communication with Data Logger software.
- USB port provides mobile device charging plus flash drive connection.
- Smartflow Data Logger PC software included.

Specifications:

Housing.....NEMA4X compliant
 Operating Temperature.....0°C to 52°C (32°F to 125°F)
 Maximum Wireless Range.....20 meters (65.5 ft)
 Maximum Tracer_{VM} Base Flowmeter
 Distance to Bluetooth I/F.....3 meters (10ft)
 Power required8 to 28VDC with earth ground (external)
 Cord grips.....9 pieces liquid-tight (included)
 Data logging software.....included



TracerVM Base

Mobile App

Tracer_{VM} Mobile App is available for free download from iTunes or the Google Play store. Search for "Tracer_{VM}". The mobile app displays temperature and flow rate data from one Interface module with up to 8 flowmeters at one time.

Functions:

- Saves .csv file to USB data storage device connected to the Bluetooth Interface Module for archiving and analysis.
- Display and data logging options include:
 - * Name Interfaces
 - * Name individual cooling circuits on the device
 - * Name .csv file
 - * Manual or Scheduled duration
 - * Selectable log rate between 1 and 3600 seconds
 - * Metric or English units

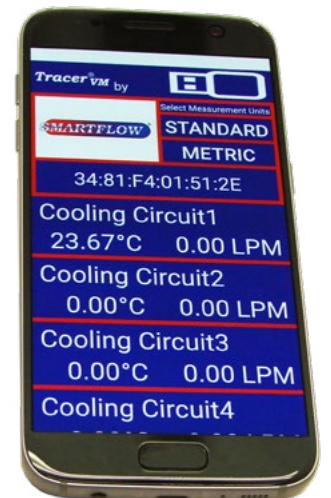

VMBTI-100 Enclosure Dimensions

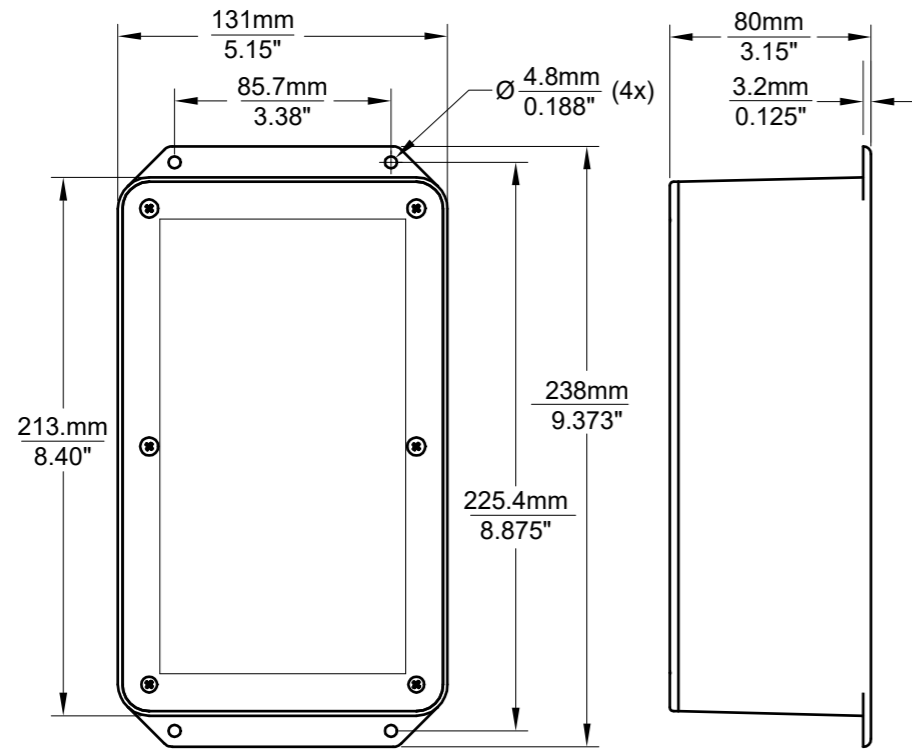

Data Logger (PC Based Software)

The Data Logger Software is provided to you free of charge as a .zip file via USB flash drive or internet download. The Data Logger displays temperature and flow rate data from up to 10 Tracer_{VM} Interface Modules with each module on a separate tab.

Functions:

- Saves .csv file to specified location for archiving and analysis.
- Display and data logging options include:
 - Name Interfaces
 - Name individual cooling circuits in the session (display only)
 - Name .csv file
 - Manual or Scheduled duration
 - Selectable log rate between 1 and 3600 seconds
 - Metric or English units
 - Set alerts for low or high temperature and flow rates
 - View real-time graph for each Tracer_{VM} Base unit. View data from each Tracer_{VM} Interface module in individual tabs.

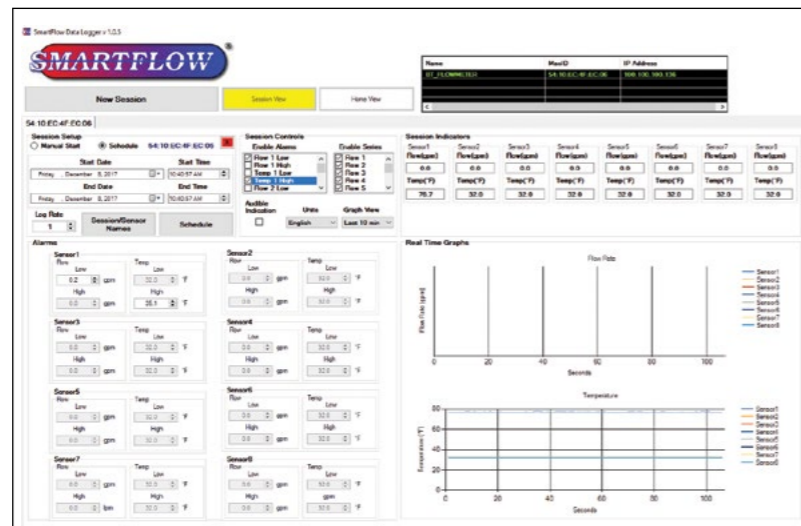

PC-Based **Smartflow Data Logger Software** provides temperature and flow process data that can be used in database software for reference and analysis. These data records are useful to injection molders maintaining compliance to regulatory requirements and quality control.

Two screen views are available: Home View and Session View.

Home View

The Home View displays graphs of temperature and flow cooling water conditions for all Tracer_{VM} Base flowmeters connected to Tracer_{VM} Bluetooth Interfaces. Up to 10 Interfaces can be displayed graphically on one screen. The maximum number of Tracer_{VM} Bluetooth Interface Units visible for selection is 30. The Home View can show overall health of cooling water lines across the shop floor. An unexpected value for flow or temperature can be seen quickly and may be an indication of a blocked cooling line or out-of-tolerance processing conditions resulting in poor molded part quality.

Session View

Session view displays one Tracer_{VM} Bluetooth Interface with temperature and flow values for each connected Tracer_{VM} Base flowmeter. A maximum of eight flowmeters can be viewed on the screen in Session View. A maximum of 10 Interfaces can be accessed as tabs in the session view at one time.

Log files are created in Session View. These can be started manually or scheduled as needed. Maximum recorded log length is 72 hours.

Session Controls box allow users to set alerts for low or high temperature and flow conditions. When data is being recorded, an alert will pop up on screen to notify the user when a parameter has been breached. The indicator will disappear as soon as the condition that caused the alert has cleared. Alerts are disabled when recording is not active.

Session Indicators at the top of the screen display current temperature and flow values from Tracer_{VM} Base Flowmeters that are connected to the selected Interface_{VM}. Real Time Graphs are also displayed for each flowmeter connected to the Interface. Unused flowmeter locations may be disabled as needed. Active Interface units are selected via tabs located near the top of the screen



Home View



Session View

DD - TRACER WITH FLUID CHARACTERISTIC INDICATION (FCI) TECHNOLOGY



With the new Tracer Electronic Flowmeter, it is easier than ever to know exactly how much water is flowing through your water lines. In addition to flow rate, the Tracer™ provides a precise temperature reading of the water. It will calculate BTU's and display "TFLOW" message when Turbulent Flow is present. With the new information the Tracer™ will provide, you can manage your processes more completely and accurately.

Know Your Flow

There is no need to guess if water is flowing through each line or zone of a mold. Now you can know exactly how much is flowing. Your flow rate is displayed in 100ths of a gallon per minute. If you prefer, flow is displayed in liters per minute.

Know Your Water Temperature

In addition to providing current flow rate data, the Tracer™ also provides the current water temperature at the flowmeter. Used on the supply side, this can verify precise water temperature as it enters the mold. Put the Tracer™ in the out or return side and measure water temperature exiting the mold. Temperature can be displayed in either Fahrenheit or Celsius units, user selectable.

Know Your BTU's

The setup mode of the Tracer™ allows you to enter the incoming or supply water temperature. Then with the Tracer™ attached to the return water line, it will calculate BTU per minute.

Know Your FCI's

Tracer flowmeter displays a special message ("TFLOW") when Turbulent Flow is present in your cooling water. Turbulent flow is the condition of optimum cooling efficiency. Tracer flowmeter calculates this condition based on the cooling water line size, water temperature and percentage of glycol (0, 10% 20% or 30%) as input in the setup mode.

Versatile

The Tracer™ can be mounted in any position. It can accept flow in either direction. 3/8" units include a sight glass on the back for visual verification of flow. Select the optional quick-connect fittings and use the Tracer™ as a test kit to diagnose your water line problems.

Digital LCD Display

The digital display Tracer™ is battery powered and has an easy-to-read LCD which displays flow rate, temperature or BTU's at the touch of a button. A programmable auto shutoff feature extends battery life.

REF	Inlet/Outlet	Temp. Range	Temp. Accuracy	Flow	Flow Accuracy	Weight
DD3B	3/8" BSP inlet and outlet	0-82 °C	± 2%	2-30 lpm	± 5%	0,7 kg
DD3BB	3/8" BSPP inlet and outlet	0-82 °C	± 2%	2-30 lpm	± 5%	0,7 kg

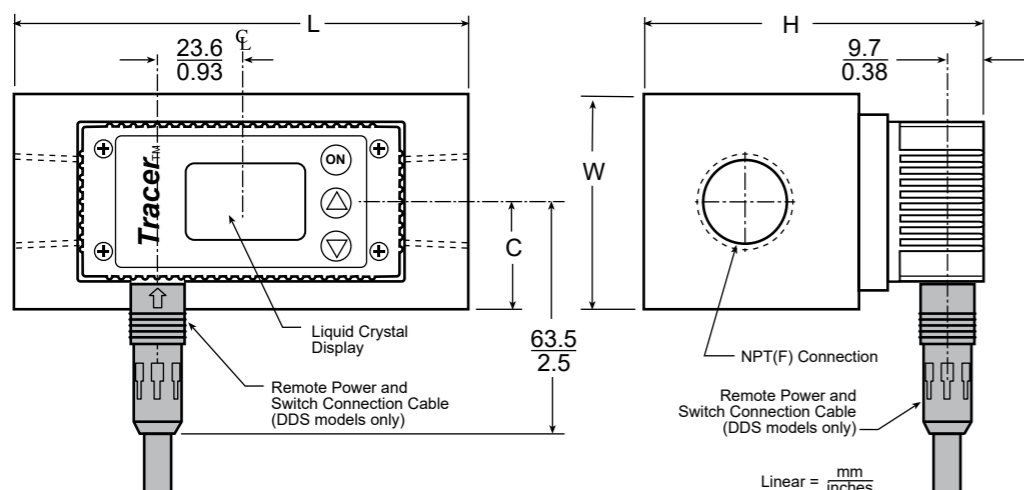

F - MECHANICAL FLOWMETERS

Features

- Compact, rugged design
- 99° (210 °F) temperature rating
- Operating pressure 6,9 bar max
- Max flow 75lpm
- Aluminum body
- Polysulfone sight glass
- Can be mounted in any position
- Optional thermometer & pressure gauge

Materials & Options

- Body.....Anodized aluminum
- Sight glassPolysulfone
- Gasket.....Neoprene
- VaneStainless steel
- SpringStainless steel
- Pin & screws.....Stainless steel
- Thermometer (opt.).....0° 250°F/-20° -120°C
- Pressure gauge (opt.)0 to 100 PSI

REF	Flow	Measurement	Inlet/Outlet
F06BA75	7 - 75 lpm	Flow	3/4" BSP
F06BB75	7 - 75 lpm	Flow and temperature	3/4" BSP
F6BC375	7 - 75 lpm	Flow, temperature and pressure	3/4" BSP

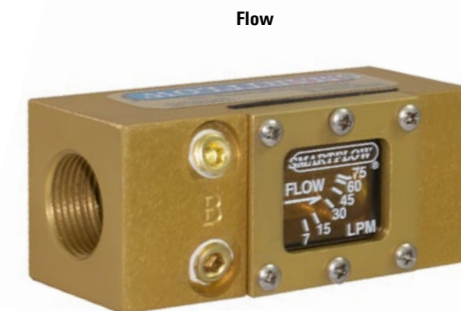

Flow & Temp.



Flow, Temp. & Pressure

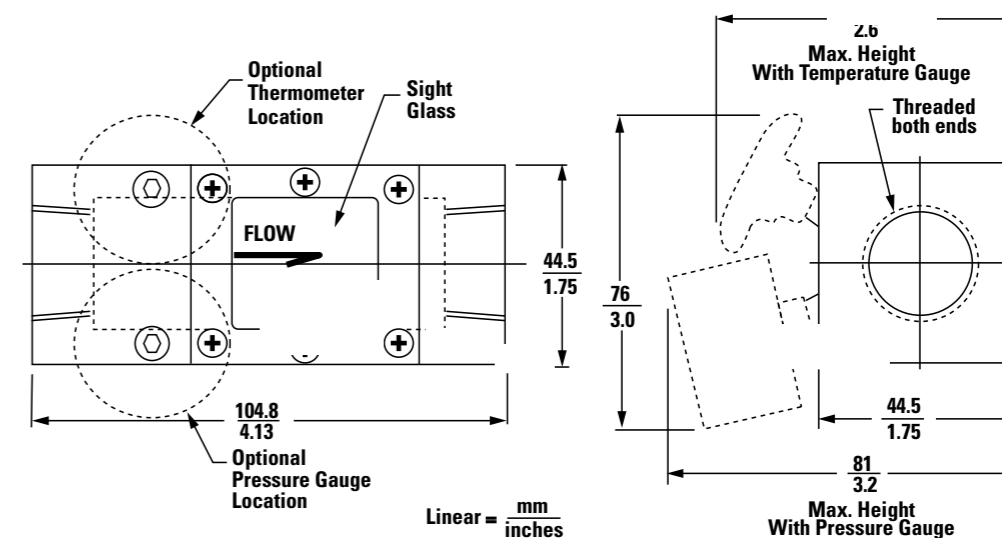
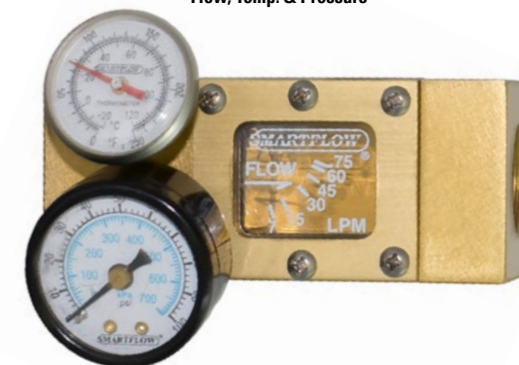

FP - ICECUBE™ FLOWMETERS WITH NYLON END CAPS

REF	Flow range	Measurements	Inlet Size
FP3BA30	4 – 30 lpm	Flow	3/8 " BSP
FP3BC30	4 – 30 lpm	Flow, temperature and pressure	3/8 " BSP

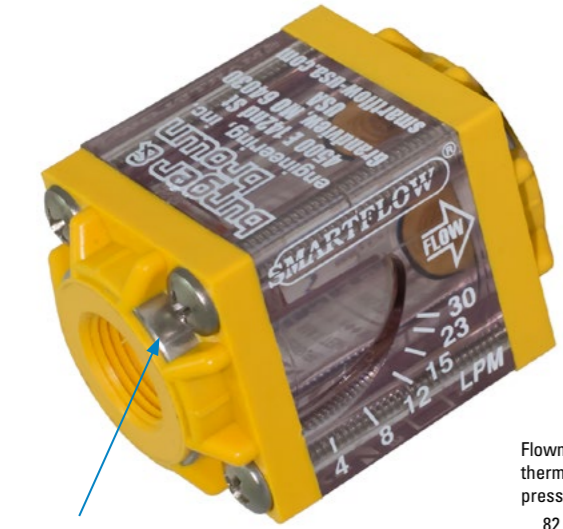

Stainless Steel Stabilizer Ring!

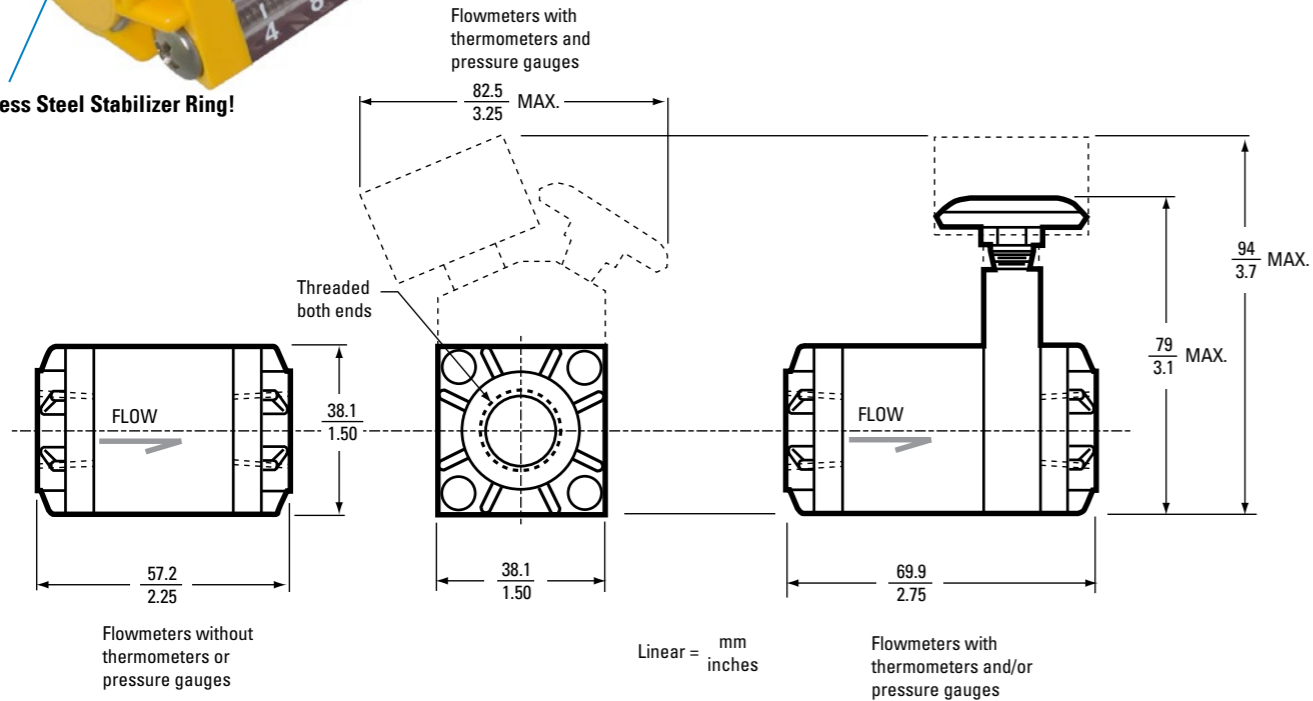

Reinforced Nylon End Caps reduce weight and cost of proven mechanical flowmeter design. Stainless steel stabilizer ring holds threads stable, preventing distortion. Nylon material provides dielectric insulator to help prevent galvanic action due to dissimilar metals.

General Description

Smartflow® Mechanical Flowmeters are durable, vane-operated devices that provide visual indication of flow rate in many different styles and sizes. Rugged wetted parts are compatible with many process liquids. Optional temperature and pressure gauges add functionality and flexibility to Smartflow® Flowmeters. Brass quick-connect fittings are available to create an excellent, portable tool for determining flow and locating clogged lines.

Features and Benefits

- Compact size works well in restricted-space locations
- Rugged construction gives years of dependable service
- 99°C (210°F) temperature rating allows installation into a wide range of applications
- Optional temperature and pressure gauges display pressure and temperature information in addition to flow in one unit

- No mounting restrictions ease installation in any position without extra brackets or hardware

Wetted Parts and Materials

- End CapsGlass-filled nylon
- Flow BodyPolysulfone
- VaneGlass-filled nylon
- Spring.....Stainless steel
- O-Rings.....EPDM
- Cap ScrewsStainless steel
- Optional Quick-Connect Fittings.....Brass

Specifications

- Flow Accuracy±10% full scale
- Operating Temperature.....99°C max. (210°F max.)
- Operating Pressure.....100 PSI max. (6.9 bar max.)
- Dial Thermometer.....-20° to 120°C (0° to 250°F)
- Pressure Gauge0 to 700 Kpa (0 to 100 psi)
-±2% accuracy (full scale)
-±3% accuracy (full scale)

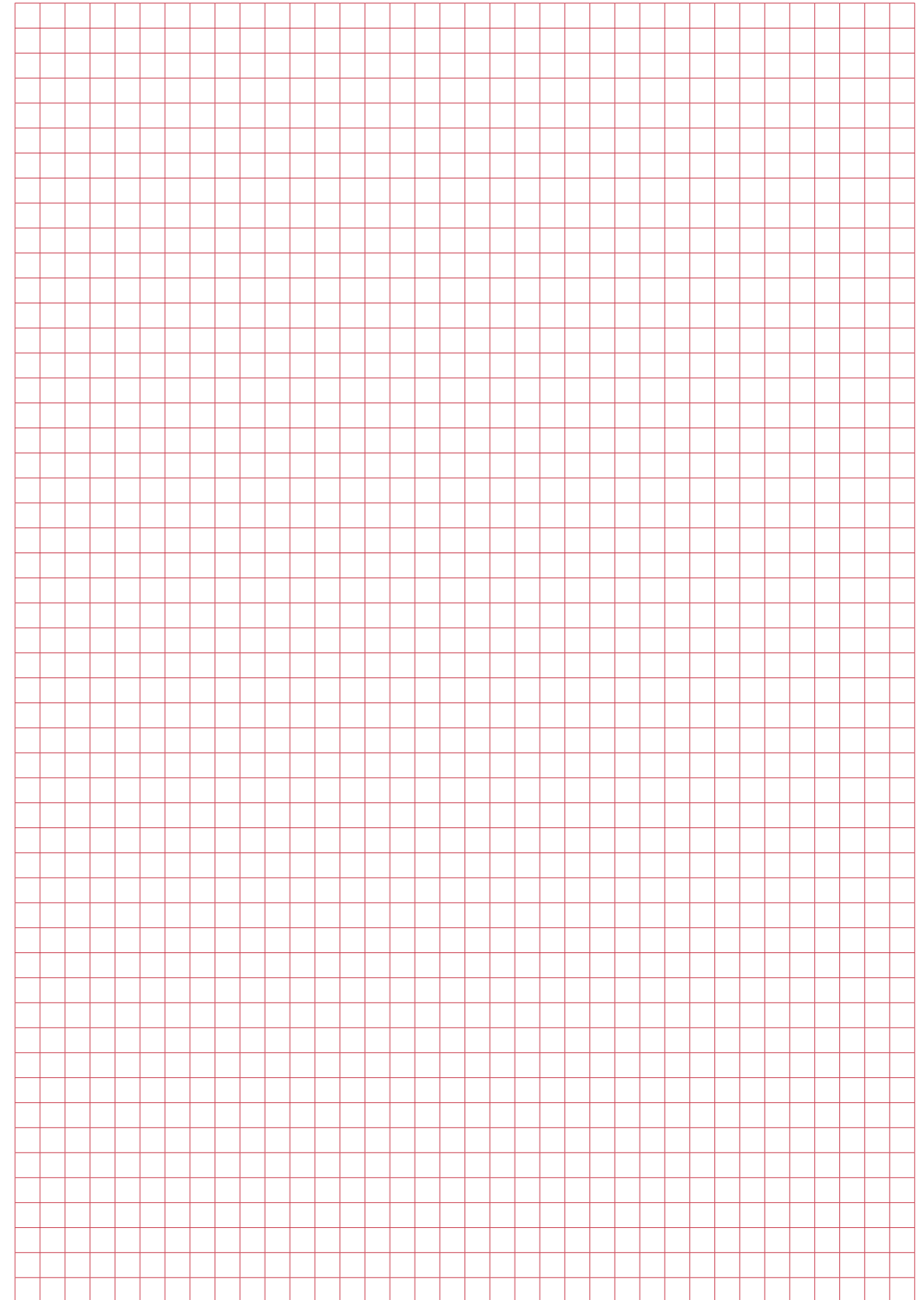



FROM PELLET TO PART
YOUR PARTNER FOR PRODUCTIVITY AND SUSTAINABILITY

Order
Online



eSTORE
store.dme.net

Available
Online 24/7



Or Call Our Customer Care Team

AT
P: 800 301 60
F: 800 401 020
dme_oesterreich@dme.net

DE
P: 800 664 82 50 | +49 (0) 2351 437 0
F: 800 664 82 51 | +49 (0) 2351 437 220
dme_normalien@dme.net

IT
P: 800 089 734
F: 800 089 735
dme_italy@dme.net

SK
P: 800 142 451 | +420 572 151 754
F: 800 142 450 | +420 571 611 996
dme_cz@dme.net

BE
P: +32 (0) 15 28 87 30
F: +32 (0) 15 40 51 17
dme_benelux@dme.net

ES
P: 900 900 342
F: 900 900 343
dme_iberia@dme.net

NL
P: +31 (0) 20 654 5571
F: +31 (0) 20 654 5572
dme_benelux@dme.net

UK
P: +44 2071 3300 37
F: +44 2071 3300 36
dme_uk@dme.net

CH
P: +41 0848 567 364
F: +41 0848 567 365
dme_schweiz@dme.net

FR
P: +33 1 49 93 92 23
F: +33 1 49 93 92 22
dme_france@dme.net

PL
P: +800 331 1312 | +32 15 21 50 92
F: +800 331 1313 | +32 15 40 51 92
dme_polska@dme.net

Other countries
P: +32 15 28 87 30
F: +32 15 40 51 17
dme_export@dme.net

CZ
P: 800 142 451 | +420 572 151 754
F: 800 142 450 | +420 571 611 996
dme_cz@dme.net

HU
P: 0680 205 003 | +32 15 28 87 30
F: +32 15 40 51 17
dme_hungary@dme.net

PT
P: 800 207 900
F: 800 207 901
dme_iberia@dme.net